

# Electric & Hybrid Boom Lifts

## NEW DESIGN ELECTRIC ARTICULATING BOOM WITH DIESEL MODEL PERFORMANCE.

EC520AJ was especially designed for both indoor and outdoor applications. Combined electric boom with diesel boom features, including zero emission, low noise and rough terrain, ground clearance performance, EC520AJ can cover more applications than others, which support better utilization for customers. EC520AJ is equipped with Lithium Ion Battery, maintenance free and less charging time, which provide EC520AJ higher efficiency.

### Key Features



Lithium Ion battery, together with AC Electric motor, provide diesel-like power performance.



Outstanding rough terrain functionality with diesel model chassis, big ground clearance and oscillating axle.

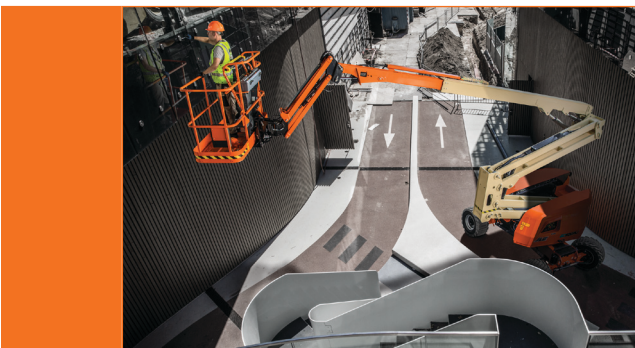

Zero emission and environment friendly. Better utilization with indoor and outdoor applications coverage.

# EC520AJ Series Specifications

EC520AJ	
Platform Height	16 m
Horizontal Outreach	10.65 m
Up and Over Height	7.3 m
Swing	355° Non-Continuous
Platform Capacity	250 kg
Platform Rotator	180°
Jib (Range of Articulation)	145° (+76, -69)
A. Platform Size	0.76 x 1.83 m
B. Overall Width	2.35 m
C. Tailswing	Zero
D. Stowed Height	2.27 m
E. Stowed Length	7.77 m
F. Wheelbase	2.36 m
G. Ground Clearance	42 cm
Weight*	7,985 kg
Ground Bearing Pressure***	6.6 kg/cm <sup>2</sup>
Drive Speed	4.5 km/h
Gradeability	30%
Turning Radius (Inside)	2.06 m
Turning Radius (Outside)	4.78 m
Tire Size/Type	315/55 D20 Foam-Filled
Electrical System	48V DC
Batteries	4 x 24V, 144 amp-hr, Lithium Ion battery
Drive Motors	Dual Electric Traction AC
Brakes	Spring Applied Multiple Discs
Hydraulic Motor/Pump	Perm. Magnet Motor/Gear Pump
Hydraulic Reservoir	30 L

\*Certain options or country standards increase weight.  
 \*\*\*Ground bearing pressure applies to standard tires.  
 Specifications may change to meet country standards or with addition of optional equipment.

## Reach Diagrams

EC520AJ

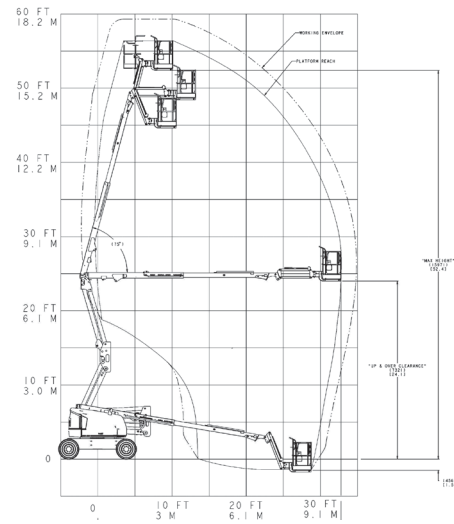

## Dimensions

