

MOVE THE WORLD FORWARD  MITSUBISHI
HEAVY
INDUSTRIES
GROUP

HIGH-LEVEL ORDER PICKERS

EOP Series (1.3 TON)

WHEN
RELIABILITY IS
EVERYTHING...

 **MITSUBISHI**
FORKLIFT TRUCKS

EXTRAORDINARY

DESIGNED TO

***SAVE TIME
& ENERGY***

FOR OPTIMUM THROUGHPUT

Designed to improve work efficiency and simplify order picking process inside workplaces, the new Mitsubishi **EOP15N3** is an industry-leading performance truck that runs up to 2 shifts per battery charge. Not only is it complementary with a comprehensive range of optional productivity features, it also empowers you the **WINGS** to reach out for **MORE** loads with extended run time, leaving with more time to focus on what is most important.

Currently only available in a single truck capacity that holds up to 1.3 ton, the EOP15N3 actually provides superb performance by equipping your business with an ultimate machine designed to deliver exceptional reliability and value.



PERFORMANCE

***UNBEATABLE
VERSATILITY***

***WORK LONGER
WORK SMARTER***



ADVA AT A GLANCE



NTAGES



Superior Lifting Performance

Lifts up to 9.3 meters without compromising the truck stability while achieving excellent lift capacity retention.



One Charge, Double Productivity

Perform up to 16 operating hours on one single battery charge in most applications thus helping you to maximize your business value and saves money.



Advanced 3 Phase AC Technology: Dynamic Speeds and Performance to Spare

Mitsubishi EOP15N3 provides you with all the power you need in terms of performance. Not only is it capable of delivering strong acceleration, it also offers high lift / lower speeds with an exceptional powerful rated motors that results in low energy consumptions and longer run times for efficient order picking.



Top Travel Speeds:

- Up to **12km/h** in drive unit direction
- Up to **0.38m/s** when lifting
- Up to **11km/h** in fork direction
- Up to **0.47m/s** when lowering



Sealed Components: 1,000 hour Service Intervals

The new Mitsubishi EOP15N3 is built with sealed components which provide added protection in dusty or moist environments, thus requiring less maintenance over time. Supremely energy-efficient, its extended 1,000-hour service intervals help reduces the need for routine checks and lesser downtime.



Sealed Component

GET THE **JOB DONE** WITH **CONFIDENCE**

ERGONOMIC PRODUCTIVITY

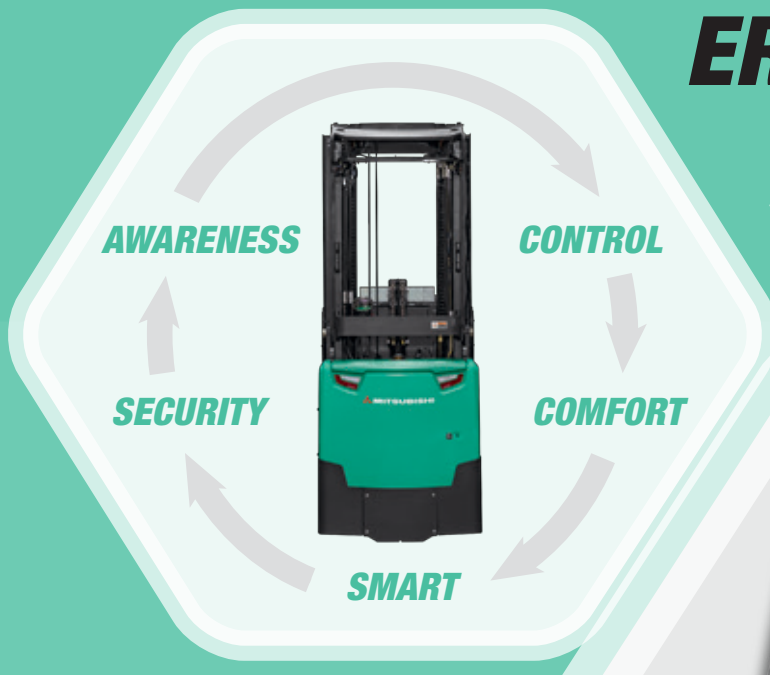

1. **AWARENESS**

- Features an interactive display panel which shows key performance indicators in full colour
- Easy to configure truck settings via display
- 3 different performance modes to choose from. Operators can easily navigate through different operator levels according to their expertise and preferences
- Enhanced forward and upward visibility with enlarged clear vision mast guard

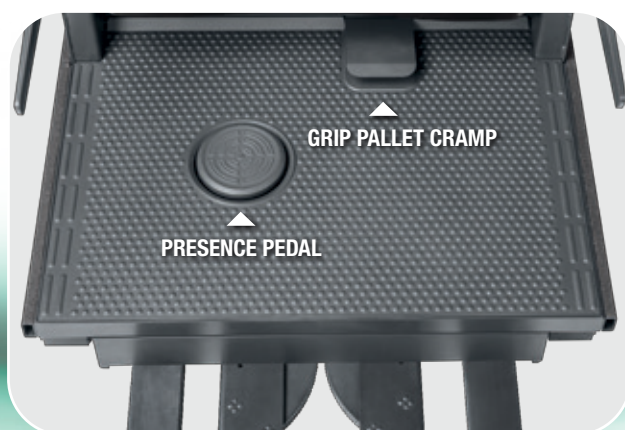

2. **COMFORT**

- Generous wide operator platform allows adequate room for the operator to adjust stance, incorporates an ultra-comfort cushioned floor mat to reduce fatigue and productivity over extended shift hours
- Large presence foot switch provides an easier transition to position the foot from the floor pad to the pedal

ICE

ACTIVITY SMART



3. CONTROL

- Curve control feature automatically reduces speed when turning corners at elevated height
- Full electric steering for less effort required to manoeuvre the truck
- Intuitive multifunctional control features in hand-grip allows easy handling of both hydraulic and travel movement while on the move



4. SECURITY

- Automatic pallet grip with industry leading design features a 5 inch wide opening, allowing wide variety of pallet to be centred and secured for added stability
- Retractable side gates keep the operator body confined within the operator compartment for personal protection



5. SMART Performance Options

- **Advanced Platform Visibility** - Operators can gain full visibility underneath the operator platform to ensure that the path is clear before lowering
- **Shelf Positioning System**
- **Load Weight Indicator**
- **Inductive Guidance (Wire Guide) System**

*For more information on features and benefits, please contact your local dealership

VALUABLE OPTIONS

FOR GREAT

Options For Every Warehouse

Stable and safe, the new **Mitsubishi EOP15N3**, high-level order picker is a highly configurable truck that is specially designed to adapting to most high-level order picking application needs.

Compact, functional and robust along with extensive options, EOP15N3 not only looks just as good as you'd expect from any high-level order picker, it also represents the essence of Mitsubishi's design spirit and is set to boost your order picking efficiency and performance to the next level.



● **Dual fans**

Designed with the operator in mind for optimum comfort.

● **LED lights**

Durable, enhanced brightness which increases visibility under low lights condition in aisle area.

● **USB power port**

Available in single or dual ports, with 5 Volt /2 amps to power up electronic device while on the move.

● **Freezer conditioning**

Includes display with an integrated heater, wire mesh mast guard and additional components designed to withstand cold environment.

● **Furniture picking**

Available in various fork length options, the new Mitsubishi EOP15N3 also comes with a tether pole that is essential for handling longer loads at high level. This allows operators to manipulate the load and move across the platform with ease.

ER PRODUCTIVITY

Aisle Guidance Options

Available in either **Wired** or **Rail guidance** options, the new Mitsubishi EOP15N3's easy operation allows the operator to experience much more efficient order picking process that sees the truck being automatically guided within the aisle for an entire throughput.

*Includes programmable performance features such as travel speed and lift height control



Rail Guidance



Wire Guidance



Available Configurations

Customization at its best. Optimize **ergonomics** and **productivity** in your warehouse with these brilliant options.

- Choose between the 24 and 36-Volt power option
- 4 battery compartment options to choose from: 362mm, 413mm, 464mm and 540mm
- 5 simplex masts ranging from 3500mm to 5400mm
- 9 triplex masts ranging from 5000mm to 9300mm
- 7 base leg width sizes ranging from 1067mm to 1575mm long
- 11 fork lengths which ranges from 760mm to 2440mm and adjustable from side-to-side
- Wire or rail guidance options
- Wide range of operator platform widths (standard is 1067mm)

SPECIFICATIONS

CHARACTERISTICS		EOP15N3 (short chassis)		EOP15N3 (long chassis)	
1	Type	High-level Order Picker		High-level Order Picker	
2	Power voltage	24 / 36		24 / 36	
3	Capacity at rated load center	lb	kg	3,000	1,360
4	Capacity load center – distance from fork face	in	mm	24	600
DIMENSIONS					
5	Maximum fork height ²⁾	in	mm	238	6,046
6	Fork dimensions – length x width x thickness	in	mm	42 x 4 x 2	1,280 x 100 x 50
7	Fork spacing – out-to-out minimum	in	mm	24 / 30	610 / 762
8	Fork carriage width ¹⁾	in	mm	30	762
9	Load distance (load axle to fork face)	in	mm	6.5	165
10	Wheelbase	in	mm	61.2	1,554
11	Extended mast height (including platform) ²⁾	in	mm	327	8,310
12	Overhead guard height (top)	in	mm	92	2,337
13	Lowered mast height	in	mm	107	2,721
14	Lowered platform height	in	mm	10	245
15	Maximum platform height	in	mm	248	6,291
16	Overall length (with 42" L forks installed)	in	mm	120	3,040
17	Length to fork face (includes fork thickness)	in	mm	78.0	1,980
18	Overall width – chassis / wheel legs	in	mm	40 / 42	1,016 / 1,067
19	Ground clearance at lowest point	in	mm	0.45	12.0
20	Ground clearance at center of wheelbase	in	mm	1.9	47.2
21	Minimum outside turning radius	in	mm	71.2	1,808
23	Length to tip of wheel arms	in	mm	27.6	702
24	Inside operator compartment height	in	mm	81.1	2,060
25	Top of fork to top of overhead guard	in	mm	89.0	2,263
26	Top of fork to floor height	in	mm	6.5	166
27	Operator compartment floor to side gate arm	in	mm	38.3	972
28	Ground to top of fork when fully lowered	in	mm	3.0	75
29	Ground to top of battery rollers	in	mm	8.0	203
30	Pallet clamp opening width	in	mm	5.7	145
PERFORMANCE					
31	Travel speed, loaded / no load	mph	km/h	7.5 / 7.5	12 / 12
32	Lift speed, loaded / no load	fpm	m/s	67 / 77	0.35 / 0.39
33	Lowering speed, loaded / no load	fpm	m/s	93 / 81	0.47 / 0.41
34	Brakes – service			regenerative	regenerative
35	Brakes – parking			electric spring-loaded	electric spring-loaded
WEIGHT					
36	Service weight	lb	kg	5,730	2,600
37	Service weight with maximum weight battery, no load	lb	kg	8,030	3,642
38	Service weight with minimum weight battery, no load	lb	kg	7,680	3,484
39	Axle loading, no load, front / rear	lb	kg	4,467 / 3,563	2,026 / 1,616
40	Axle loading with rated load, front / rear	lb	kg	2,778 / 8,270	1,260 / 3,751
CHASSIS					
41	Tires			polyurethane	polyurethane
42	Tire size back (load) – based on 42" or 44" W baseleg ³⁾	in	mm	6 x 2.88	152 x 74
43	Tire size front (drive)	in	mm	13.5 x 5.5	343 x 140
44	Wheels, number, front / rear (x=drive wheels)			1x / 4	1x / 4
45	Tread width (center of tires) ¹⁾	in	mm	37.8	960
ELECTRICAL					
46	Drive motor rating S ₂ 60 min.	hp	kW	9.3	6.9
47	Lift motor rating at S ₃ 15%	hp	kW	16	12
48	Battery compartment size (L x W x H)	in	mm	38.4 x 16.25 x 32.49	975 x 413 x 825
49	Battery weight, minimum / maximum	lb	kg	1,950 / 2,300	885 / 1,043
OTHER					
50	Controls – drive / hydraulic			AC	AC

1) Based on standard (common) configuration of truck with 42" baselegs.

2) Based on common mast configuration of 238" MFH.

3) For baselegs wider than 44", wheel size is 6" x 4" (152 x 99 mm).

4) Based on common 16.25" battery compartment.

EOP15N3

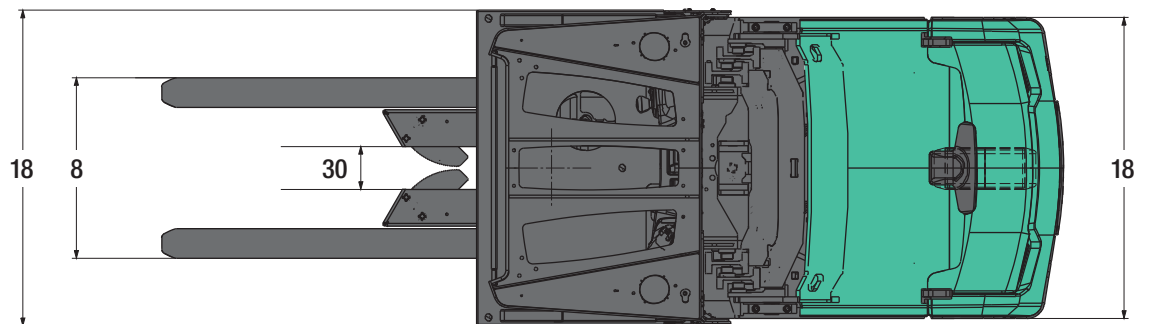
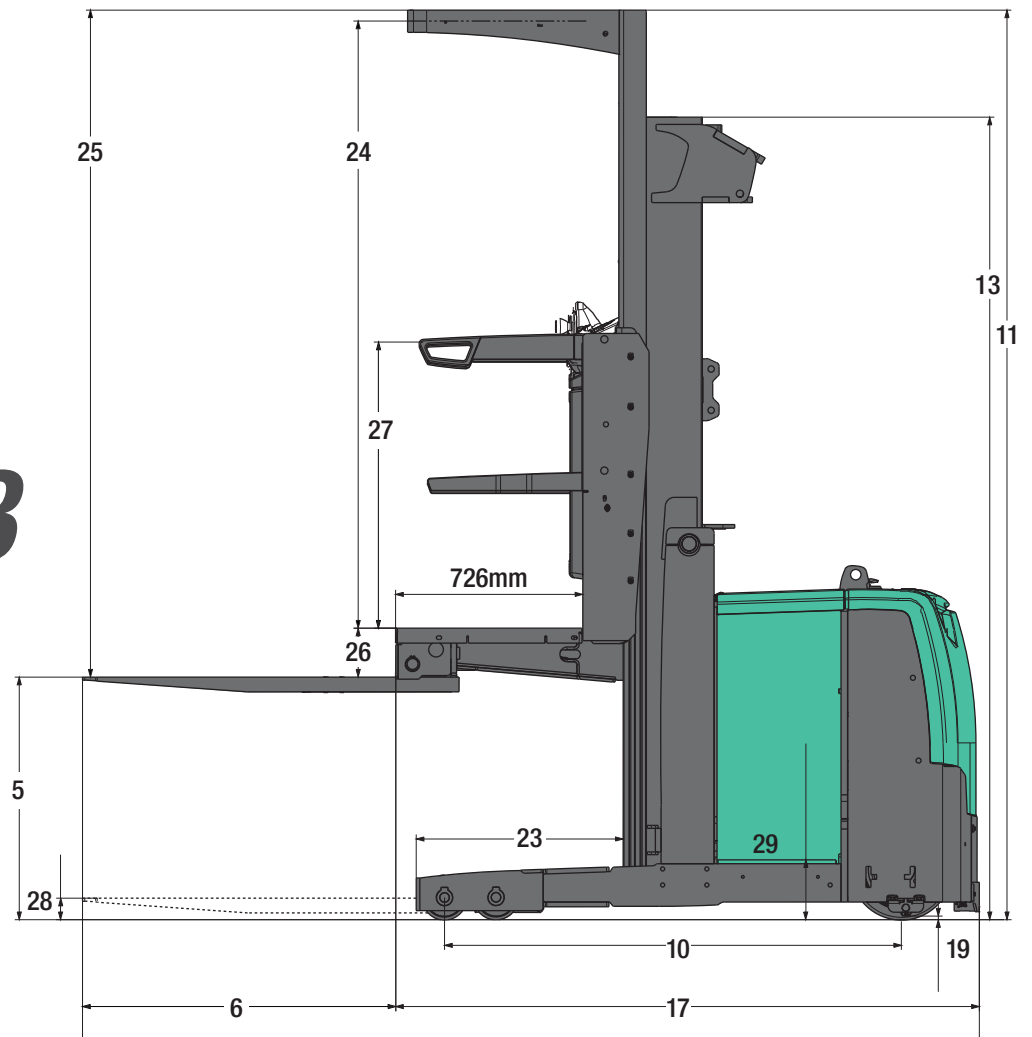

SAFETY STANDARDS

These trucks meet American National Standards Institute/Industrial Truck Standards Development Foundation, ANSI/ITSDF B56.1. UL-Classified by Underwriters Laboratories, Inc., as to fire and electric shock hazard only; Type E, EE (optional), Industrial Trucks. Users should be aware of, and adhere to, applicable codes and regulations regarding operator training, use, operation and maintenance of powered industrial trucks, including:

- ANSI/ITSDF B56.1.
- NFPA 505, fire safety standard for powered industrial trucks - type designations, areas of use, maintenance and operation.
- Occupational Safety and Health Administration (OSHA) regulations that may apply.

Specifications, equipment, technical data, photos and illustrations based on information at time of printing and subject to change without notice. Some products may be shown with optional equipment.

Like any product bearing the "MITSUBISHI" name our materials handling equipment benefits from the tremendous heritage, huge resources and cutting-edge technology of one of the world's largest corporations – Mitsubishi Heavy Industries Group.

Engineering spacecraft, jet planes, power plants and more, MHI specialises in those technologies where performance, dependability and superiority decide your success or failure...

So when we promise you quality, reliability and value for money, you know it's a guarantee we have the power to deliver.

That's why every model in our award-winning and comprehensive range of lift trucks and warehouse equipment is built to a high specification – to ensure it keeps working for you. Day after day. Year after year. Whatever the job. Whatever the conditions.

YOU'LL NEVER WORK ALONE

As your local authorised dealer, we are here to keep your trucks working – through our extensive experience, our technical excellence and our commitment to customer care.

We are your local experts, backed by efficient channels to the entire organisation of Mitsubishi Forklift Trucks.

No matter where you are, we are close by – with the capability to meet your needs.

Discover how Mitsubishi Forklift Trucks give you more from your local authorised dealer or when you visit our website www.mitforklift.com.sg

Performance specifications may vary depending on standard manufacturing tolerances, vehicle condition, types of tyres, floor or surface conditions, applications or operating environment. Trucks may be shown with non-standard options. Specific performance requirements and locally available configurations should be discussed with your distributor of Mitsubishi forklift trucks. We follow a policy of continual product improvement. For this reason, some materials, options and specifications could change without notice.

© 2020 by MLAP. All Rights Reserved. All registered trademarks are the property of their respective owners. Printed in Singapore.

FMIT0138-02 (06/2020)

