

Model 660SJC

TELESCOPIC BOOM LIFTS



MORE ECONOMIC

- Lower hydrocarbon, carbon monoxide, particulate and NOx emissions with Stage IIIB-compliant engine.

MORE PRODUCTIVE

- Equipped with track drive for easier manoeuvrability in soft environments.

MORE ACCESS

- Large work envelope including an articulating jib for a wider range of motion.

SMART DESIGN

- Fewer buttons and switches used to position the platform and less time spent learning to use the platform controls.



Standard Features

- 0.91 m x 1.83 m low mount platform
- Side entry with drop bar mid rail
- Multiple function operation
- Full proportional drive joystick control with integral thumb steer switch
- Full proportional main boom and swing joystick control
- Multiple speed control for telescope and platform rotate
- Selectable creep speed on drive / lift and swing functions
- 1.83 m articulating jib
- 180 degree powered platform rotator
- Platform console machine status light panel ¹
- Load sensing system
- AC cable to platform
- Engine distress warning/shut down system ²
- Gull-wing hoods
- 3 degree tilt alarm and indicator light
- Steel tracks
- Lifting/tie down lugs
- Hour meter
- Ground control selector switch with key lock
- Platform tool tray
- 12V DC auxiliary power
- Hydraulic oil cooler
- Cast Aluminum Control Box
- Horn
- Hydrostatic drive transmission
- Swing-out engine tray
- Control ADE[®] Advanced Design Electronics System
- JLG Skyguard active system

¹ Provides indicator lights at platform control console for system distress, low fuel, tilt light, and foot switch status.

² Low oil pressure and high coolant temperature alarms with shut-down enabled/disabled by analyser.

Standard Specifications

Power Source	
• Diesel Engine - Deutz TD 2.9 L4	50kW
• Fuel Tank Capacity	148 L
Hydraulic System	
• Hydraulic System	141 L
• Auxiliary Power	12V DC

³ Available when integrated with the SkyPower[®] package.

⁴ Includes all-motion alarm and flashing amber beacon.

⁵ Includes platform mounted work lights and head & tail lights.

⁶ Includes console cover, boom wipers and cylinder bellows.

Accessories & Options

- 0.91m x 2.44m slide bar side entry platform
- 0.91m x 2.44m Self closing inward swing gate
- 13 mm air line to platform
- Rubber Track Pads
- On-board 4,000 W generator
- SkyPower[®] package 7,500 watt on-board generator
- SkyWelder[®] package 250 amp welder in the platform ³
- All motion alarm
- Alarm package ⁴
- Light package ⁵
- Head and tail lights
- Flashing amber beacon
- Euro Plug & Socket
- Hostile environment kit ⁶
- Skyguard beacon (ILOS)
- Arctic package
- Generator hourmeter
- Synthetic Biodegradable Hydraulic Oil
- Platform worklights
- Special paint colour

Model 660SJC

TELESCOPIC BOOM LIFTS

Performance

• Working Height	22.31 m
• Working Outreach	17.95 m
• Swing (continuous)	360°
• Platform Capacity – Unrestricted	230 kg
• Platform Rotator (hydraulic)	180°
• Jib – Overall Length	1.83 m
• Jib – Range of articulation	130° (+70°-60°)
A. Platform Size	0.91 m x 1.83 m
B. Overall Width	2.49 m
C. Tailswing (working condition)	1.10 m
D. Stowed Height	2.56 m
E. Overall Length	10.74 m
F. Ground Clearance	0.38 m
• Stowed Length	10.21 m
• Machine weight ¹	12,300 kg
• Maximum Ground Bearing Pressure	0.457 kg/cm ²
• Drive Speed	2.6 km/h
• Gradeability	55%
• Turning Radius	Zero
• Type of Tracks ²	Steel
• Tracks Width	0.50 m

¹ Certain options or country standards may increase weight and/or dimensions.

² Optional detachable rubber pads available



Reach Diagram

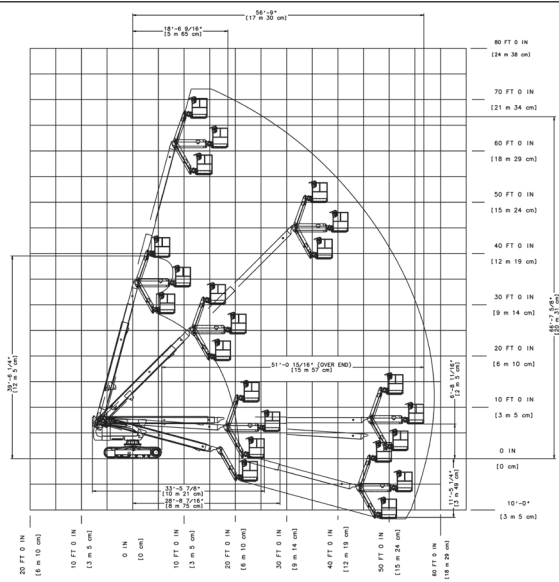

Dimensions

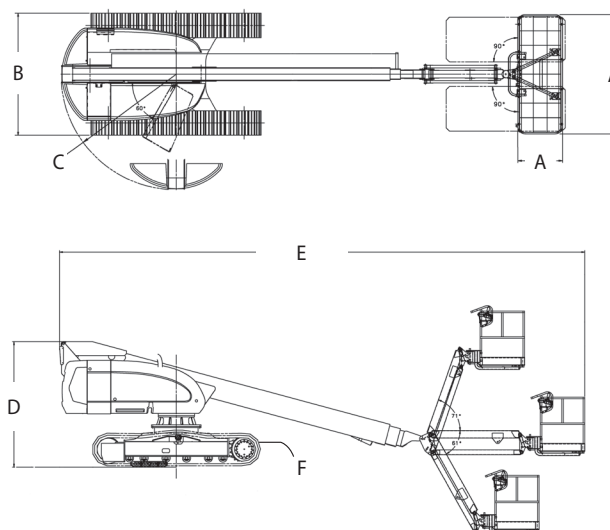

IMPORTANT

JLG is continually researching and developing products and reserves the right to make modifications without prior notice. All data in this document is indicative. Certain options or country standards will increase weight. Specifications may change to meet country standards or with the addition of optional equipment.

Due to continuous product improvements, JLG Industries reserves the right to make specification and/or equipment changes without prior notification.



JLG EMEA BV

Polaris Avenue 63
2132 JH Hoofddorp
The Netherlands
Tel: +31 (0)23 565 5665
Fax: +31 (0)23 557 3750
www.jlg.com

An Oshkosh Corporation Company