

MOVE THE WORLD FORWARD  MITSUBISHI
HEAVY
INDUSTRIES
GROUP

PREMIA **ES** (1.6 - 2.0 TONS)

PEDESTRIAN POWER PALLET & DOUBLE PALLET TRUCKS



PBP16-20N2(R)(E)/PBP16PD Series

WHEN
RELIABILITY IS
EVERYTHING...

 **MITSUBISHI**
FORKLIFT TRUCKS

OVERCOME YOUR OBSTACLES... ACHIEVE OUTSTANDING PERFORMANCE

Whether you are upgrading from a hand pallet truck, doing short shuttle work or looking for a truck prepared to go the distance, there is a **PREMiA** model which will meet your needs.

With **PREMiA ES**, anything is possible – including outdoor operation if that's what you need. It's possible on most models, thanks to high-stability, market-leading lift heights and outstanding ingress protection.

These low-maintenance models feature an easy-to-use tiller arm design, protects otects hands and places everything within easy reach for safe, comfortable, controlled operation.

FRAME AND BODY

- **Sealed chassis** offers protection against dirt, dust and other particles to reduce wear (not available on PBP16PD).
- **Water-resistant design** diverts splashed moisture away from key electrical components, for long truck life (not available on PBP16PD).
- **High stability** is ensured by use of two linked castor wheels – next to the central drive wheel – in addition to the load wheels (not available on PBP16PD).
- **Low centre of gravity** adds further stability, for safe operation.

BRAKES

- **Regenerative braking** gives effective control, without brake wear, and extends shift life
- **Parking brake** is automatically activated, when necessary, for extra safety on ramps.

STEERING SYSTEM

- **State-of-the-art tiller arm** offers the ultimate in ergonomic design, comfort and safety.
- **Small turning circle** together with compact chassis and excellent visibility means exceptional manoeuvrability.





DRIVE

- **Powerful AC drive motor** is placed above the chassis plate, safeguarding it against the elements (not available on PBP16PD).
- **Oil-filled, sealed transmission** is shock-resistant, quiet and requires little maintenance (not available on PBP16PD).

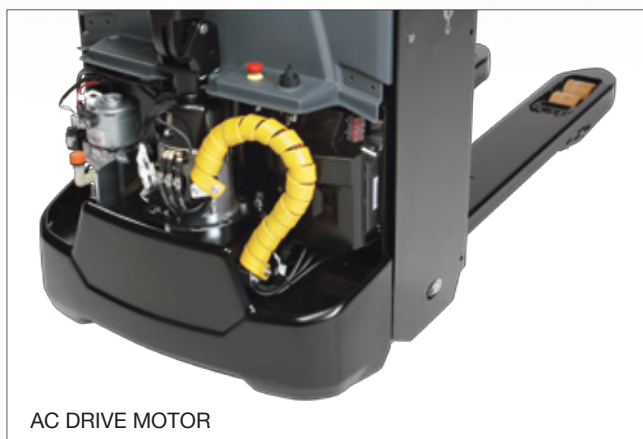

AC DRIVE MOTOR

MAST AND FORKS

- **Robust forks** with welded construction, and rounded tips for effortless pallet entry, give extra strength and durability.
- **Market-leading lift height of 135 mm** allows easy handling on steep ramps and loading docks, even with damaged pallets (not available on PBP16PD).

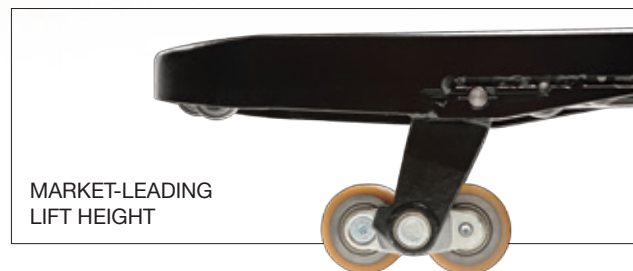

MARKET-LEADING
LIFT HEIGHT

- **Tapered forks** enhance safety, while offering quicker and easier access to pallets in racks or block stacks.
- **Rising forks** on PBP20N2E place loads at an ergonomic height - maximum 735 mm - for loading & unloading with minimal physical strain.

WORK WITH GREATER PRODUCTIVITY



ELECTRICAL AND CONTROL SYSTEMS

- **Programmable controller** adjusts acceleration, travel speed and braking to suit the application and operator - for greater versatility.
- **On-board diagnostics and fault memory folder** speed up servicing and help prevent damage.
- **High-efficiency electronic system** features waterproof components for maximum reliability - even in moist conditions (not available on PBP16PD).

Operator Environment and Controls

Creep speed function and tiller arm lock bypass maximise safety and control in confined spaces.



Easy-to-operate controls reduce operator fatigue and minimise mistakes to enhance safety.

Unique crossbar design deflects obstacles away from tiller arm and operator's hand, protecting both truck and operator.



Ergonomically shaped rubber hand grips are comfortable and slip-free, allowing for easy reach of controls (not available on PBP16PD).

Choice of two performance modes via key switch enhances safety, energy efficiency and productivity (not available on PBP16PD).



Battery discharge indicator is fitted as standard for battery protection and monitoring of truck use.

Ground clearance is only 35 mm – which makes foot trapping very unlikely.



Spacious, suspended foldable platform on PBP20N2R allows operator to ride in comfort - maximum speed 6 km/h - during occasional longer travel.

OTHER FEATURES

- **RapidAccess features** allow quick and easy entry to all areas for checks and maintenance.
- **PIN-code access** prevents unauthorised use of the truck (PBP16PD only).



SPECIFICATIONS

CHARACTERISTICS			
1	Manufacturer		Mitsubishi Forklift Trucks
2	Manufacturer's model designation		PBP16N2
3	Power source		Battery
4	Operator type		Pedestrian
5	Load capacity	Q kg	1600
6	Load center distance	c mm	600
7	Load wheel axle to fork face (forks lowered)	x mm	960
8	Wheelbase	y mm	1360
WEIGHT			
9	Truck weight without load, with maximum battery weight	kg	431
10	Axle loadings with nominal load & maximum battery weight, drive / load side	kg	635 / 1396
11	Axle loadings without load & with maximum battery weight, drive / load side	kg	332 / 99
WHEELS, DRIVE TRAIN			
12	Tyres: PT = Power Thane, Vul = Vulkollan, P = Polyurethane, N = Nylon, R = Rubber drive / load side		Vul / Vul
13	Tyre dimensions, drive side	mm	230 x 70
14	Tyre dimensions, load side	mm	85 x 90
15	Castor wheel dimensions (diameter x width)	mm	100 x 40
16	Number of wheels, load / drive side (x = driven)		2 + 1x / 2
17	Track width (center of tyres), drive side	b10 mm	480
18	Track width (center of tyres), load side	b11 mm	355 / 375 / 495
DIMENSIONS			
19	Height with mast lowered	h1 mm	–
20	Lift height	h3 mm	135
21	Height with mast extended	h4 mm	–
22	Initial lift	h5 mm	–
23	Seat- or stand height	h7 mm	–
24	Height of tiller arm / steering console (min./max.)	h14 mm	1050 / 1372
25	Fork height, fully lowered	h13 mm	85
26	Overall length	l1 mm	1648
27	Length to fork face	l2 mm	498
28	Overall width	b1/b2 mm	720
29	Fork dimensions (thickness, width, length)	s/e/l mm	55 / 165 / 1150
30	Fork carriage width	b5 mm	520 / 540 / 660
31	Outside width over forks (minimum / maximum)	m2 mm	30
32	Working aisle width (Ast) with 1000 x 1200 mm pallets, load crosswise, platform up/down	Ast mm	1694
33	Working aisle width (Ast) with 800 x 1200 mm pallets, load lengthwise	Ast mm	–
34	Working aisle width (Ast3) with 800 x 1200 mm pallets, load lengthwise	Ast3 mm	–
35	Working aisle width (Ast) with 800 x 1200 mm pallets, load lengthwise, platform up/down	Ast mm	1894
36	Turning radius	Wa mm	1454
PERFORMANCE			
37	Travel speed, with / without load	km/h	6.0 / 6.0
38	Lifting speed, with / without load	m/s	0.035 / 0.045
39	Lowering speed, with / without load	m/s	0.05 / 0.05
40	Gradeability, with / without load	%	10.0 / 20.0
41	Acceleration time (10 metres) with / without load	s	–
42	Service brakes (mechanical / hydraulic / electric / pneumatic)		Electric
ELECTRIC MOTORS			
43	Drive motor capacity (60 min. short duty)	kW	1.0
44	Lift motor output at 15% duty factor	kW	0.8
45	Battery voltage/capacity at 5-hour discharge	V/Ah	24 / 150
46	Battery weight	kg	151
MISCELLANEOUS			
47	Type of drive control		Stepless
48	Level of noise at the ear level of the driver according to EN 12 053:2001 and EN ISO 4871 in work LpAZ	dB(A)	–
49	Level of noise at the ear level of the driver according to EN 12 053:2001 and EN ISO 4871, drive/lift/idle LpAZ	dB(A)	62 / 69 / 0
50	Whole-body vibration (EN 13 059:2002)		–
51	Hand-arm vibration (EN 13 059:2002)		< 2.5

1) With 375Ah battery the l2 dimension increases 72mm

PEDESTRIAN POWER PALLET TRUCKS
**PBP16N2, PBP18N2 &
PBP20N2 SERIES**
1.6 – 2.0 TONS

Mitsubishi Forklift Trucks	Mitsubishi Forklift Trucks
PBP18N2	PBP20N2
Battery	Battery
Pedestrian	Pedestrian
1800	2000
600	600
960	960
1424	1424
502	634
806 / 1496	864 / 1770
381 / 121	475 / 159
Vul / Vul	Vul / Vul
230 x 70	230 x 70
85 x 75	85 x 75
100 x 40	100 x 40
2 + 1 x / 4	2 + 1 x / 4
480	480
355 / 375 / 495	355 / 375 / 495
-	-
135	135
-	-
-	-
-	-
1050 / 1372	1050 / 1372
85	85
1712	1712
562	562
720	720
55 / 165 / 1150	55 / 165 / 1150
520 / 540 / 660	520 / 540 / 660
30	30
1758	1758
-	-
-	-
1958	1958
1518	1518
6.0 / 6.0	6.0 / 6.0
0.035 / 0.045	0.04 / 0.06
0.05 / 0.05	0.05 / 0.05
10.0 / 20.0	10.0 / 20.0
-	-
Electric	Electric
1.0	1.0
0.8	1.2
24 / 250	24 / 250 - 375 ¹⁾
212	212-294
Stepless	Stepless
-	-
62 / 69 / 0	65 / 67 / 0
-	-
< 2.5	< 2.5

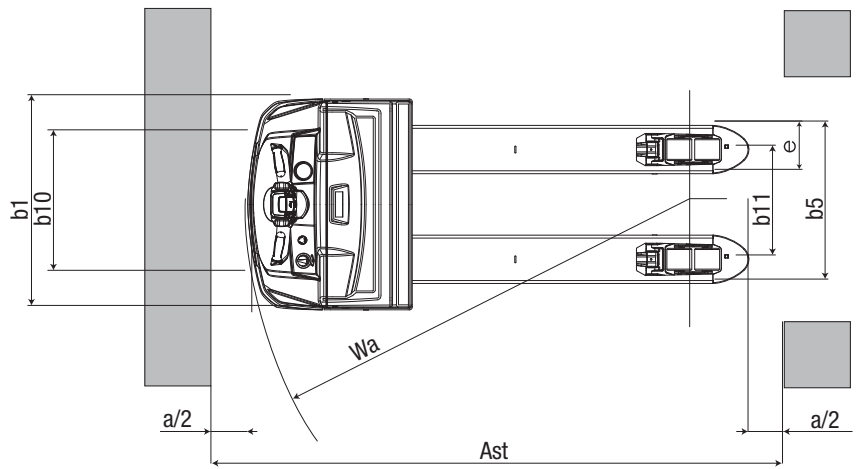
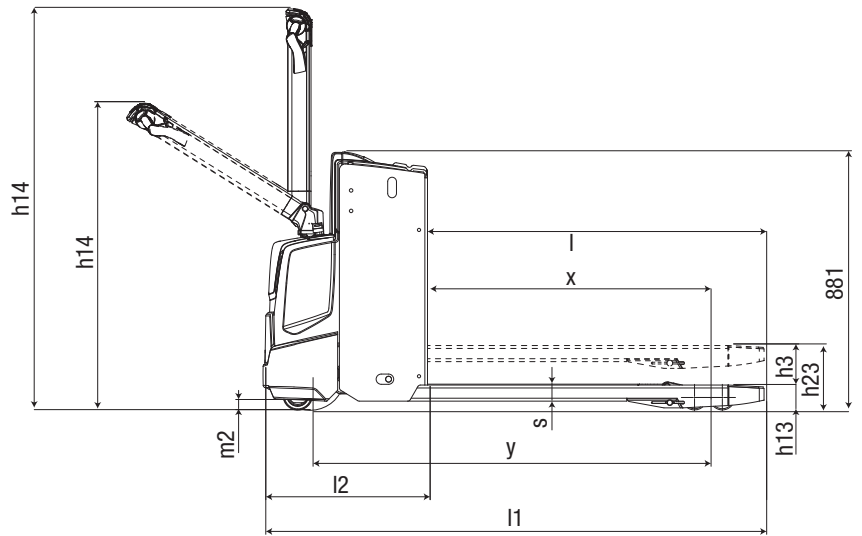

$Ast = Wa - x + l6 + a$
Ast = Working aisle width
Wa = Turning radius
a = Safety clearance (200 mm)
l6 = Pallet length

SPECIFICATIONS

CHARACTERISTICS				
1	Manufacturer		Mitsubishi Forklift Trucks	Mitsubishi Forklift Trucks
2	Manufacturer's model designation		PBP16PD	PBP20N2R
3	Power source		Battery	Battery
4	Operator type		Pedestrian	Pedestrian
5	Load capacity	Q kg	1600 / 800 + 800	2000
6	Load center distance	c mm	600	600
7	Load wheel axle to fork face (forks lowered)	x mm	990	960
8	Wheelbase	y mm	1510	1421
WEIGHT				
9	Truck weight without load, with maximum battery weight	kg	800	595
10	Axle loadings with nominal load & maximum battery weight, drive / load side	kg	990 / 1410	890 / 1705
11	Axle loadings without load & with maximum battery weight, drive / load side	kg	590 / 210	470 / 125
WHEELS, DRIVE TRAIN				
12	Tyres: PT = Power Thane, Vul = Vulkollan, P = Polyurethane, N = Nylon, R = Rubber drive / load side		Vul / Vul	Vul / Vul
13	Tyre dimensions, drive side	mm	230 x 70	230 x 70
14	Tyre dimensions, load side	mm	85 x 99	85 x 75
15	Castor wheel dimensions (diameter x width)	mm	140 x 60	125 x 55
16	Number of wheels, load / drive side (x = driven)		1 x + 1 / 4	2 + 1 x / 4
17	Track width (center of tyres), drive side	b10 mm	382	480
18	Track width (center of tyres), load side	b11 mm	355	375
DIMENSIONS				
19	Height with mast lowered	h1 mm	1400 / 1550	–
20	Lift height	h3 mm	1700 / 2000	135
21	Height with mast extended	h4 mm	2145 / 2445	–
22	Initial lift	h5 mm	120	–
23	Seat- or stand height	h7 mm	–	172
24	Height of tiller arm / steering console (min./max.)	h14 mm	913 / 1368	1180 / 1350
25	Fork height, fully lowered	h13 mm	90	85
26	Overall length	l1 mm	1864	1854 / 2346
27	Length to fork face	l2 mm	664	702 / 1195
28	Overall width	b1/b2 mm	660	720
29	Fork dimensions (thickness, width, length)	s/e/l mm	65 / 185 / 1200	50 / 165 / 1150
30	Fork carriage width	b5 mm	540	540
31	Outside width over forks (minimum / maximum)	m2 mm	25	30
32	Working aisle width (Ast) with 1000 x 1200 mm pallets, load crosswise, platform up/down	Ast mm	NA	1920 / 2400
33	Working aisle width (Ast) with 800 x 1200 mm pallets, load lengthwise	Ast mm	2532	–
34	Working aisle width (Ast3) with 800 x 1200 mm pallets, load lengthwise	Ast3 mm	2290	–
35	Working aisle width (Ast) with 800 x 1200 mm pallets, load lengthwise, platform up/down	Ast mm	–	2120 / 2600
36	Turning radius	Wa mm	1880	1680 / 2160
PERFORMANCE				
37	Travel speed, with / without load	km/h	5.6 / 6	6.0 / 6.0
38	Lifting speed, with / without load	m/s	0.10 / 0.20	0.03 / 0.05
39	Lowering speed, with / without load	m/s	0.12 / 0.12	0.07 / 0.08
40	Gradeability, with / without load	%	6 / 19	9.0 / 20.0
41	Acceleration time (10 metres) with / without load	s	7.94 / 6.76	–
42	Service brakes (mechanical / hydraulic / electric / pneumatic)		Electric	Electric
ELECTRIC MOTORS				
43	Drive motor capacity (60 min. short duty)	kW	1.3	1.0
44	Lift motor output at 15% duty factor	kW	2.35	1.2
45	Battery voltage/capacity at 5-hour discharge	V/Ah	24 / 150 - 230	24 / 250 - 375 1)
46	Battery weight	kg	140 - 215	212-294
MISCELLANEOUS				
47	Type of drive control		Stepless	Stepless
48	Level of noise at the ear level of the driver according to EN 12 053:2001 and EN ISO 4871 in work LpAZ	dB(A)	74.6 +/- 0.7	–
49	Level of noise at the ear level of the driver according to EN 12 053:2001 and EN ISO 4871, drive/lift/idle LpAZ	dB(A)	–	63 / 78 / 0
50	Whole-body vibration (EN 13 059:2002)		–	0.9
51	Hand-arm vibration (EN 13 059:2002)		–	< 2.5

1) With 375Ah battery the l2 dimension increases 72mm

Ast = Wa-x+l6+a

Ast = Working aisle width

Wa = Turning radius

a = Safety clearance (200 mm)

l6 = Pallet length

h3+h13 = Lifting height

h1 = Lowered mast height

h2+h13 = Free lift

Mitsubishi Forklift Trucks
PBP20N2E
Battery
Pedestrian
2000 / 700
600
875
1509
579
770 / 1809
419 / 160
Vul / Vul
230 x 70
85 x 75
100 x 40
2 + 1 x / 4
480
375
-
735
-
135
-
1050 / 1372
90
1780
653
720
50 / 195 / 1150
570
30
1874
-
-
2074
1526
6.0 / 6.0
0.11 / 0.14
0.13 / 0.12
9.0 / 20.0
-
Electric
1.0
1.2
24 / 150
151
Stepless
-
59 / 60 / 0
-
< 2.5

PEDESTRIAN DOUBLE PALLET TRUCK PBP16PD 1.6 TONS

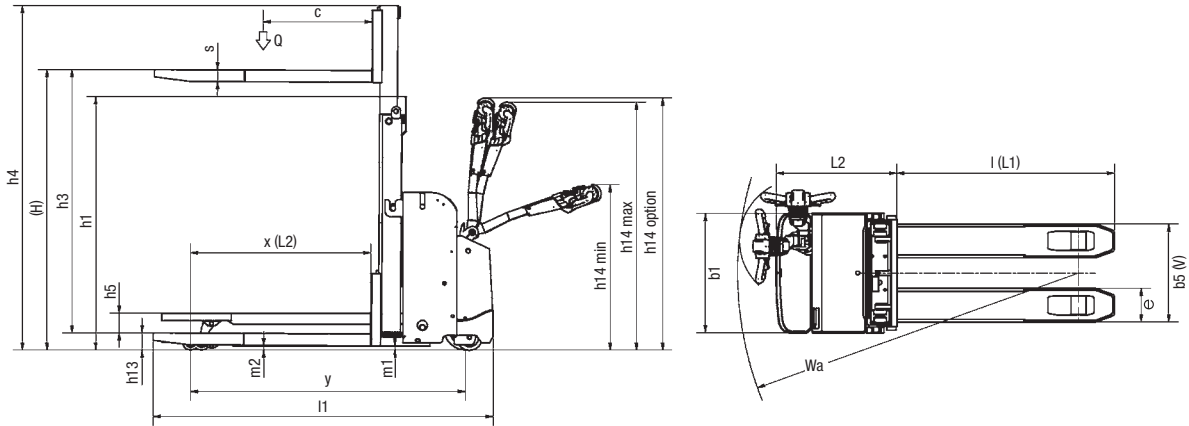

MAST TYPE	h3 + h13 mm	h1* mm	h2 + h13 mm
PBP16PD			
DUPLEX	1675	1410	NA
	2090	1560	NA

Mast Performance and Capacity

- h1 = Height with mast lowered
- h2 = Standard free lift
- h3 = Lift height
- h4 = Height with mast raised
- h5 = Full free lift
- Q = Lifting capacity, rated load
- c = Load centre (distance)

* h1 closed mast height includes polycarbonate finger protection. Mast height excl. Finger protection is 1343mm / 1493mm.

PEDESTRIAN POWER PALLET TRUCKS PBP20N2R 2.0 TONS WITH FOLDING PLATFORM

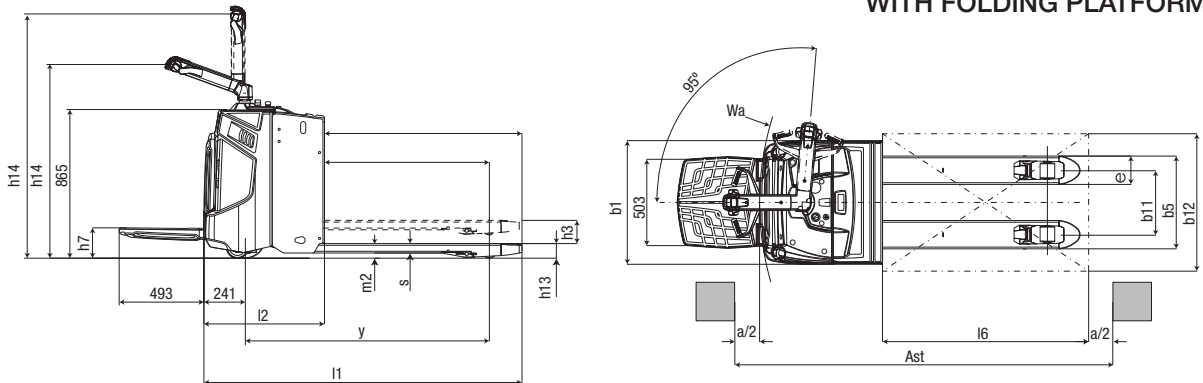

PEDESTRIAN DOUBLE PALLET TRUCKS PBP20N2E 2.0 TONS WITH RISING FORKS

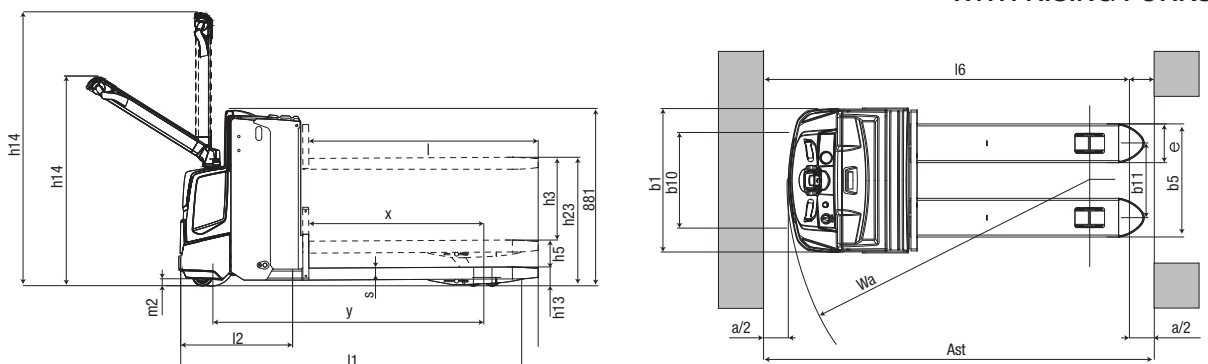

STANDARD EQUIPMENT & OPTIONS

● = Standard

▲ = Option

	PBP16N2	PBP18N2	PBP20N2
GENERAL			
Led battery discharge indicator, no hourmeter	●	●	●
Micro-computer incl. Hour meter and battery indicator with cut out (ATC T4)	-	-	-
PIN code log in 100 codes	-	-	-
PIN code log in 4 codes	▲	▲	▲
Offset tiller arm with display and keypad	-	-	-
Chill store design, down to 1°C, with rust protected axles	-	-	-
Electric on/off valve for lifting and lowering, controlled by rocker switch on tiller head	●	●	●
Polyurethane drive wheel or rubber	-	-	-
Initial lift	-	-	-
Single or tandem load wheels polyurethane	●	●	●
ENVIRONMENT			
Cold store design, 0°C to -35°C	▲	▲	▲
Hot operating condition modification, >30°C	▲	▲	▲
DRIVE AND LIFT CONTROLS			
Heavy duty tiller Head - with key switch entry	-	-	-
Tiller in line with chassis contour	-	-	-
Tiller up drive	●	●	●
Fingertip levers on tiller arm, lift & lowering	▲	▲	▲
WHEEL OPTIONS			
Polyurethane traction and load wheels	●	●	●
Power friction traction wheel	▲	▲	▲
Tandem polyurethane load wheels	▲	●	●
Single polyurethane load wheels	▲	●	●
Non marking drive wheel	-	-	-
Anti static drive wheel	-	-	-
OTHER OPTIONS			
Rubber foot protection	-	-	-
Diselectric band	-	-	-
Key switch	●	●	●
Capacity 2000kg on straddles	-	-	-
Piezo buzzer instead of standard horn	-	-	-
Load backrest	▲	▲	▲
Special RAL colour	▲	▲	▲
In-built charger 30A	▲	▲	▲
Sideways battery change, 250A and 375Ah battery only	-	▲	▲
Battery changing device	-	▲	▲
Accessory rack	▲	▲	▲
Working light	▲	▲	▲

PEDESTRIAN POWER PALLET AND
DOUBLE PALLET TRUCKS
**PBP16 – 20N2(R)(E) &
PBP16PD Series**
1.6 – 2.0 TONS

PBP16PD	PBP20N2R	PBP20N2E
-	●	●
●	-	-
●	-	-
-	▲	▲
●	-	-
●	-	-
●	●	●
●	-	-
●	-	●
●	●	●
▲	▲	▲
-	▲	▲
▲	-	-
▲	-	-
▲	●	●
●	▲	▲
●	●	●
▲	▲	▲
●	●	●
●	●	●
▲	-	-
▲	-	-
-	●	●
▲	-	-
▲	-	-
▲	▲	▲
▲	▲	▲
-	▲	▲
-	▲	-
-	▲	-
-	▲	▲
-	▲	▲



In-built charger 30A



Load backrest



Accessory rack

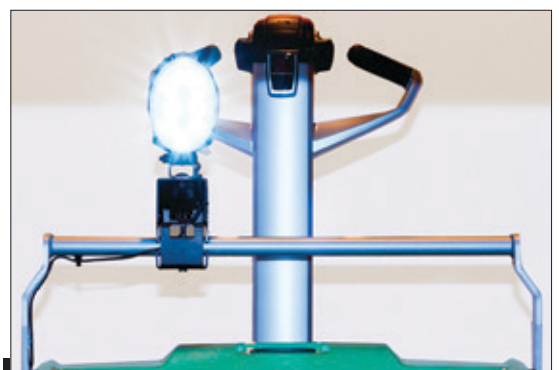

Working light

Like any product bearing the "MITSUBISHI" name our materials handling equipment benefits from the tremendous heritage, huge resources and cutting-edge technology of one of the world's largest corporations – Mitsubishi Heavy Industries Group.

Engineering spacecraft, jet planes, power plants and more, MHI specialises in those technologies where performance, dependability and superiority decide your success or failure...

So when we promise you quality, reliability and value for money, you know it's a guarantee we have the power to deliver.

That's why every model in our award-winning and comprehensive range of lift trucks and warehouse equipment is built to a high specification – to ensure it keeps working for you. Day after day. Year after year. Whatever the job. Whatever the conditions.

YOU'LL NEVER WORK ALONE

As your local authorised dealer, we are here to keep your trucks working – through our extensive experience, our technical excellence and our commitment to customer care.

We are your local experts, backed by efficient channels to the entire organisation of Mitsubishi Forklift Trucks.

No matter where you are, we are close by – with the capability to meet your needs.

Discover how Mitsubishi Forklift Trucks give you more from your local authorised dealer or when you visit our website www.mitforklift.com.sg

Performance specifications may vary depending on standard manufacturing tolerances, vehicle condition, types of tyres, floor or surface conditions, applications or operating environment. Trucks may be shown with non-standard options. Specific performance requirements and locally available configurations should be discussed with your distributor of Mitsubishi forklift trucks. We follow a policy of continual product improvement. For this reason, some materials, options and specifications could change without notice.

© 2020 by MLAP. All Rights Reserved. All registered trademarks are the property of their respective owners. Printed in Singapore.

FMIT0169 (02/2020)

