

ready to perform to your application

Developed for outstanding performance and genuine value for money, the award winning range of Mitsubishi forklift trucks and warehouse equipment is built to a higher specification to maximize productivity and ensure utter reliability... whatever the application.

It's what you'd expect from one of the world's largest corporations whose companies are at the leading edge of technologies where performance, quality and dependability can never be compromised.

It means that, from a single safe source, we can meet 98% of all handling requirements, supplied to you via range of competitive finance options including outright purchase, rental or leasing.

So your local dealer can advise you on precisely the right product for your application... and your budget.

Moreover, because we understand how much you depend on your Mitsubishi forklift truck, we deliver the highest levels of customer support.

You can find your nearest dealer at
www.mitforklift.com.sg

Mitsubishi Forklift Trucks has won **four separate Fork Lift Truck Association Annual Awards for Excellence covering the areas of **Ergonomics**, the **Environment** and **Innovation***



www.mitforklift.com.sg

©2018 by MLAP. All Rights Reserved. All registered trademarks are the property of their respective owners. Printed in Singapore.

FMIT0142-01 (03-18)

Note: Performance specifications may vary depending on standard manufacturing tolerances, vehicle condition, types of tyres, floor or surface conditions, applications or operating environment. Trucks may be shown with non-standard options. Specific performance requirements and locally available configurations should be discussed with your distributor of Mitsubishi forklift trucks dealer. Mitsubishi Forklift Trucks follows a policy of continual product improvement. For this reason, some materials, options and specifications could change without notice.

SENSIA Reach Trucks and Multi-Way Reach Trucks

1.4 – 2.5 tonnes



Ready to Perform
To Your Applications



SENSIA

CREATING DISTINCTION

Mitsubishi designed **SENSIA** – a high performance truck (capable of reaching up to 13m rack height) possess the required aspect to help operator to stop thinking about the controls, and focus on the job in hand.

SENSIA, our industry-leading fingertip controls take another leap forward: responding naturally to the pressure of your touch. Progressive steering feels perfect at every speed, while acceleration, mast and cornering are familiar and smooth. It's simply instinctive.

Yes, the truck's state-of-the-art AC drive motor and hydraulics deliver impressive speed and lifting power in a compact, stable body. Yes, **SENSIA** has Mitsubishi's legendary build quality. And yes, this is our best mast yet.

But at Mitsubishi, we know a reach truck is only as productive as its driver. So we also built a spacious, easy-access cabin that's free from distractions, ensured great all round visibility, and created a choice of custom drive modes to suit the operator's task, experience and skill.



*Picture is for illustration purpose only. Contact your dealership for more information.

IMPEL ERGONOMICS



SPACIOUS CABIN

Inside the wide open, easy-access cabin, everything is carefully designed to help the driver stay comfortable, focused and efficient – even during the longest shifts. Pedals are shaped, positioned and angled to minimise ankle stress, **while flexible, three-dimensional adjustment for the ergonomic armrest and full suspension seat** gives operators full control over their own driving position. No annoyances. No aches. Just pure productivity.



VIVID DIGITAL DISPLAY

SENSIA lets managers match the truck's drive settings to the driver and task. **PRO mode** maximise performance in the hands of an expert; **ECO mode** makes things simpler for inexperienced or part-time operators, while also prolonging battery life for a longer shift.

The **full-colour driver display** is visible from all angles, even in direct sunlight, and gives drivers simple, intuitive access to guidance, settings, warnings and alarms –reinforcing good practice, even at the busiest times. It all adds up to efficient, mistake-free handling.



FUTURISTIC FINGERTIP CONTROL

1. F2 Functional Button for additional information
2. Horn
3. Directional Drive Selector
4. Lift Level
5. Tilt Lever
6. Side-Shifter Lever

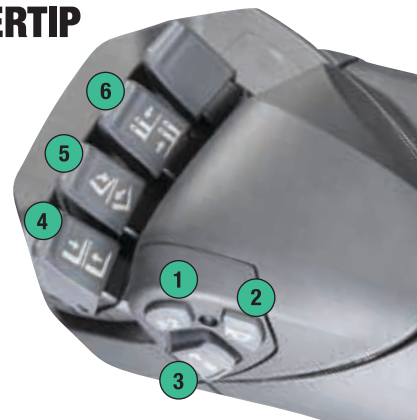

SENSITIVE DRIVE SYSTEM

Sensitive Drive System (SDS), popular with drivers for its intuitive 'feel', SDS senses whether the truck is being operated assertively or cautiously –and then delivers a smoothly modulated performance for that specific situation.

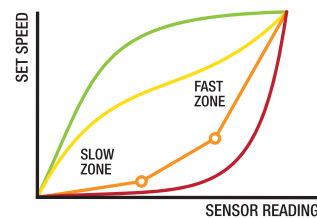

- Fast response to full speed
- Medium speed response profile
- Slow speed response profile
- Typical controller curve

MORE POWER MORE STORAGE

With powerful, AC motors, class-leading hydraulics and revolutionary mast design, **SENSiA** has the strength to lift bigger loads, to higher heights, than most other trucks of its size.

Or, to put it another way, you can have a smaller truck than you thought.

That means aisles can be smaller, operating spaces tighter, and you can make the best use of the precious space you have available.

Of course, if that's not going to slow your operators down, you also need a truck that's nimble, and easy to manoeuvre with absolute precision. Oh, and great all round visibility is a must, to give the clearest possible view of the truck, the load and the space available.

That's why **SENSiA** has **unlimited, 360-degree electric steering**, with a firm, progressive feel... and exceptional visibility through the revolutionary **Visionmast**, clear-view fork carriage and overhead guard and the open, uncluttered cabin. At any time, the operator knows exactly what's going on. And the mast design doesn't just give great visibility. It's the strongest and most stable we've ever made – with a choice of sway control systems for fast, accurate work at height... **and the confidence to deliver.**



There's no waiting for mast sway, either. You've a choice of Passive Sway Control and our award-winning Active Sway Control option, to get the load where it needs to be – quickly, and in one piece.





SENSiA cold store cabin total comfort and control at -35°C

Working in the sub-zero world of a cold store demands the very highest standards of visibility, reliability and comfort.

SENSiA Cold Store models have been designed to work productively and reliably – even in temperatures as low as -35° C.

From its cold-resistant cabling and waterproofed electrics to thermostatically controlled heaters for critical components and optimised hydraulics, SENSiA delivers – even in the harshest environments.

Spacious by design, SENSiA's controls are within easy reach reducing the risk of fatigue. Offering 360-degree visibility, our rugged steel-frame cabins feature a hi-vis crash-proof roof for an excellent upward view while protecting the operator against falling debris. Our well-insulated cold store cabins, available on all standard-sized SENSiA models, do much more than keep operators warm very efficiently.

- Energy-efficient cabin is well insulated and features 1700 W heater, for operator comfort throughout long shifts.
- Heated windows protect against frost, misting and condensation for excellent visibility and safe, productive performance.
- Rugged steel collision guard reinforces protection to bodywork and door for optimal safety.
- Spacious cabin keeps controls within easy reach for maximum productivity.
- Two-way intercom (option) enables communication with the driver, without opening the cabin door.

More reliability too...



SENSiA literally has performance to spare. Chances are, you won't find yourself pushing the truck to the limit – in speed or lifting capacity –any time soon.

And that's just one way that SENSiA minimises downtime and service costs. **Temperature-controlled drive** and lift motors prevent overheating damage. **Regenerative braking** reduces brake wear. CAN bus electrics reduce wiring, and make the truck fast and easy to fix. **Clever battery compartment design** makes changing, charging and maintenance quick, simple and safe. Quite simply, SENSiA works harder, for more of the time.



Pedestrian warning system



Super-clear heated windows

YOUR ULTIMATE BUSINESS SOLUTION



Clear, informative display



Low non-slip step



Tilting battery cover



Ergonomic hand bars

Mitsubishi reach truck is specially engineered to take any operator's performance to the next level.

With class-leading travel speeds of up to 14 km/h, SENSiA reach trucks are easily tailored to your needs with a choice of two performance modes.

- Experienced drivers will fully exploit the higher performance capability of the Professional (PRO) mode.
- New or inexperienced warehouse staff will respond to the Ecologic (ECO) mode which has been configured to work naturally and economically in any environment.

*For more specific needs, the truck's settings can be customised by a service engineer.

SENSiA drives productivity higher through its futuristic fingertip control system – the most sensitive and accurate in the world. With its progressive, modulated fingertip response curves, it delivers a 'feel' and an accuracy that put drivers in total control. Together with the ergonomic armrest, SENSiA ensures operators stay focused, safe and productive – even through the longest shifts.

- **Revolutionary Visionmast** offers unrivalled forward vision and superb lifting ability.
- **Powerful AC drive motor** provides high torque, even at fast speeds, for rapid acceleration and smooth, quiet, controlled, efficient operation – and lowers service costs.
- **High energy drive motors** and hydraulic systems deliver exceptional shift length between charges or changes.
- **Choice of two driving modes (ECO and PRO)** tailors the truck's performance profile to your precise needs.
- **PRO mode** with high performance settings gives experienced operators complete control of the truck's efficiency and performance.

options include

- Extra hydraulic valve and hoses to fork carriage
- Telescopic forks
- Lifting height indicator and pre-height selector
- Camera with monitor
- Side shift and tilt centering
- Quick battery locking system, foot operated

capacities

RB14N2S 1.4 t	RB14N2HS 1.4 t	RB16N2S 1.6 t	RB16N2HS 1.6 t
RB16N2 1.6 t	RB16N2H 1.6 t	RB16N2C 1.6 t	RB16N2HC 1.6 t
RB20N2H 2.0 t	RB20N2X 2.0 t	RB25N2X 2.5 t	



Folding steering wheel console



Ergonomic armrest controls



Comfortable pedal layout



Easy-access cabin

- **ECO driving mode** encourages natural, efficient operations – reducing fuel costs.
- **Unlimited 360-degree electric steering** gives precise control with minimal effort.
- **High efficiency regenerative braking** means effective control and reduced brake wear.
- **Sensitive Drive System (SDS)** offers precise control of mast and truck behaviours for accurate, smooth and stable performance.
- **Passive Sway Control (PSC)** significantly reduces the risk of sway to safeguard lives and loads.
- **Award-winning Active Sway Control (ASC)** available as an option offers further protection, reducing delays caused by mast sway, and ensures accurate, smooth and stable performance.
- **Maintenance interval calculator** encourages correct servicing, for optimum component life and minimum downtime.
- **Temperature control** in drive and lift motors and controllers – prevents damage from overheating.
- **Battery rollers** make changes quick, easy and safe.
- **Spacious and comfortable cabin, clear view and fast, accurate fork positioning** increases productivity and reduces risks of driver fatigue – even on the longest shifts.
- **Easy-access cabin** with ergonomic hand bars and low non-slip step provides safe and effortless entry.
- **Folding steering wheel console** with adjustment for column length and angle, lifts up for easy access and ensures optimum position for each driver.
- **Full-suspension, fully adjustable seat** keeps driver safe, comfortable and alert through the longest shifts. (Luxury seat with lumbar support, electrical height adjustment and air or mechanical suspension is available as option.)
- **Ergonomic armrest** matches driver's natural operating position and is fully adjustable – reducing fatigue.
- **Patented fingertip control system with modulated response curves** is optimised for natural movement – for precise, effortless control.
- **Intuitive joystick** for accurate control with the palm, is available as an option with fourway hydraulic valve systems.
- **Easy-to-understand display communicates key information to driver** including guidance, warnings and alarms – encouraging good practice.
- **Highlift mast**, up to 13m rack height
- **Telescopic forks options**, for deep racking application.
- Cold store modification package
- Hot environment modification
- Cold store cabin



Specifications

Characteristics														
1.1	Manufacturer		Mitsubishi	Mitsubishi	Mitsubishi		Mitsubishi	Mitsubishi	Mitsubishi	Mitsubishi	Mitsubishi	Mitsubishi	Mitsubishi	
1.2	Manufacturer's model designation		RB14N2S	RB14N2HS	RB16N2S		RB16N2HS	RB16N2	RB16N2H	RB16N2C	RB16N2HC	RB20N2H	RB20N2X	RB25N2X
1.3	Power source: (battery, diesel, LP gas, petrol)		Battery	Battery	Battery		Battery	Battery	Battery	Battery	Battery	Battery	Battery	Battery
1.4	Operator type: pedestrian, (operator)-standing, -seated		Seated	Seated	Seated		Seated	Seated	Seated	Seated	Seated	Seated	Seated	Seated
1.5	Load capacity	Q (kg)	1400	1400	1600		1600	1600	1600	1600	1600	2000	2000	2500
1.6	Load center distance	c (mm)	600	600	600		600	600	600	600	600	600	600	600
1.8	Load wheel axle to fork face (forks lowered)	x (mm)	281	199	281		199	331	249	327	228	399	389	389
1.9	Wheelbase	y (mm)	1300	1300	1300		1300	1350	1350	1400	1400	1500	1500	1500
Weight														
2.1	Truck weight with load, with maximum battery weight	(kg)	4970	5697	5191		5897	5445	6171	5109	5639	6570	7065	7156
2.3	Axle loadings without load & with maximum battery weight, drive / load side	(kg)	2041/1529	2318/1979	2041/1550		2318/1979	2114/1731	2389/2182	1958/1551	2114 / 1925	2435/2135	2620/2445	2466/2190
2.4	Axle loading, mast forward, with nominal load, drive / load side	(kg)	721/4249	814/4883	706/4486		814/4883	735/4709	833/5338	628/4480	614 / 5024	910/5660	680/6385	675/6480
2.5	Axle loading, mast retracted, with nominal load, drive / load side	(kg)	1706/3264	1983/3714	1686/3506		1983/3714	1745/3699	2020/4151	1602/3507	1759 / 3880	2020/4550	2090/4975	1947/5208
Tyres														
3.1	Tyres: PT=Power Thane, Vul=Vulkollan, drive / load side		PT	Vul	PT		Vul	PT	Vul	PT	Vul	Vul	Vul	Vul
3.2	Tyre dimensions, drive side	(mm)	Ø360*140	Ø360*140	Ø360*140		Ø360*140	Ø360*140	Ø360*140	Ø360*140	Ø360*140	Ø360*140	Ø360*140	Ø360*140
3.3	Tyre dimensions, load side	(mm)	Ø285 × 75	Ø285 × 75	Ø285 × 75		Ø285 × 75	Ø285*130	Ø285*130	Ø285 × 75	Ø285 × 75	Ø285*130	Ø285*130	Ø285*130
3.5	Number of wheels, load / drive side, (x=driven)		2 / 1x	2 / 1x	2 / 1x		2 / 1x	2 / 1x	2 / 1x	2 / 1x	2 / 1x	2 / 1x	2 / 1x	2 / 1x
3.7	Track width (center of tyres), load side	b11 (mm)	1195	1195	1195		1195	1140	1140	1025	1025	1140	1310	1310
Dimensions														
4.1	Fork tilt, forwards / backwards	α/β (°)	2 / 4	2 / 4	2 / 4		2 / 4	2 / 4	2 / 4	2 / 4	2 / 4	2 / 4	2 / 4	2 / 4
4.2	Height with mast lowered	h1 (mm)	see table	see table	see table		see table	see table	see table	see table	see table	see table	see table	see table
4.3	Free lift	h2 (mm)	see table	see table	see table		see table	see table	see table	see table	see table	see table	see table	see table
4.4	Lift height	h3 (mm)	see table	see table	see table		see table	see table	see table	see table	see table	see table	see table	see table
4.5	Height, mast extended	h4 (mm)	see table	see table	see table		see table	see table	see table	see table	see table	see table	see table	see table
4.7	Height to top of overhead guard	h6 (mm)	2200	2200	2200		2200	2200	2200	2200	2200	2200	2200	2200
4.8**	Seat- or stand height	h7 (mm)	1030	1030	1030		1030	1030	1030	1030	1030	1030	1030	1030
4.10	Height of support legs	h8 (mm)	360	360	360		360	360	360	360	360	360	360	360
4.15	Fork height, fully lowered	h13 (mm)	85	85	85		85	85	85	85	85	85	85	85
4.19	Overall length	l1 (mm)	2404	2486	2404		2486	2404	2486	2458	2558	2486	2496	2496
4.20	Length to fork face	l2 (mm)	1254	1336	1254		1336	1254	1336	1308	1408	1336	1346	1346
4.21	Overall width	b1/b2 (mm)	1270	1270	1270		1270	1270	1270	1100	1100	1270	1440	1440
4.22	Fork dimensions (thickness, width, length)	s / e / l (mm)	40 / 100 / 1150	40 / 100 / 1150	40/100/1150		40 / 100 / 1150	40 / 100 / 1150	40 / 100 / 1150	40 / 100 / 1150	40 / 100 / 1150	50 / 100 / 1150	50 / 100 / 1150	50 / 100 / 1150
4.23	Fork carriage to DIN 15173		FEM 2A	FEM 2A	FEM 2A		FEM 2A	FEM 2A	FEM 2A	FEM 2A	FEM 2A	FEM 2A	FEM 2A	FEM 2A
4.24	Fork carriage width	b3 (mm)	720	720	720		720	720	720	720	720	720	720	720
4.25	Outside width over forks (minimum / maximum)	b5 (mm)	315-710	315-710	315-710		315-710	315-710	315-710	315-710	315-710	315-710	315-710	315-710
4.26	Innerwidth of the support legs	b4 (mm)	1070	1070	1070		1070	900	900	900	900	900	1070	1070
4.28	Mast reach	l4 (mm)	463	381	463		381	513	432	510	410	582	572	572
4.32	Ground clearance at center of wheelbase, (forks lowered)	m2 (mm)	75	75	75		75	75	75	75	75	75	75	75
4.33/a	Working aisle width (Ast) with 1000 x1200 mm pallets, load crosswise	Ast (mm)	see table	see table	see table		see table	see table	see table	see table	see table	see table	see table	see table
4.34/a	Working aisle width (Ast) with 800 x1200 mm pallets, load lengthwise	Ast (mm)	see table	see table	see table		see table	see table	see table	see table	see table	see table	see table	see table
4.35	Turning radius	Wa (mm)	1541	1541	1541		1541	1629	1629	1629	1735	1749	1749	1749
4.37	Truck length including support legs	l7 (mm)	1693	1693	1693		1693	1793	1793	1793	1793	1893	1893	1893
Performance														
5.1****	Travel speed, with / without load	(km/h)	12 / 12	12 / 12	12 / 12		12 / 12	12 / 12	14 / 14	12 / 12	12 / 12	14 / 14	11 / 14	11 / 14
5.2	Lifting speed, with / without load	(m/s)	0.4 / 0.65	0.4 / 0.7	0.4 / 0.65		0.4 / 0.7	0.4 / 0.65	0.4 / 0.7	0.4 / 0.65	0.4 / 0.7	0.4 / 0.7	0.4 / 0.7	0.3 / 0.7
5.3	Lowering speed, with / without load	(m/s)	0.55 / 0.5	0.55 / 0.5	0.55 / 0.5		0.55 / 0.5	0.55 / 0.5	0.55 / 0.5	0.55 / 0.5	0.55 / 0.5	0.55 / 0.5	0.55 / 0.5	0.55 / 0.5
5.4	Reach speed, with / without load	(m/s)	0.2 / 0.2	0.2 / 0.2	0.2 / 0.2		0.2 / 0.2	0.2 / 0.2	0.2 / 0.2	0.2 / 0.2	0.2 / 0.2	0.2 / 0.2	0.2 / 0.2	0.2 / 0.2
5.8	Maximum gradeability, with / without load	(%)	10 / 15	10 / 15	10 / 15		10 / 15	10 / 15	10 / 15	10 / 15	10 / 15	10 / 15	10 / 15	10 / 15
5.9	Acceleration time (10 metres) with / without load	(s)	5.0 / 4.5	4.8 / 4.4	5.0 / 4.5		4.8 / 4.4	5.0 / 4.5	4.8 / 4.6	5.0 / 4.5	4.8 / 4.8	4.8 / 4.4	5.2 / 4.4	5.2 / 4.4
5.10	Service brake		Electric	Electric	Electric		Electric	Electric	Electric	Electric	Electric	Electric	Electric	Electric
Electric motors														
6.1	Drive motor capacity (S2 60 min. short duty)	(kW)	7.5	7.5	7.5		7.5	7.5	7.5	7.5	7.5	7.5	7.5	7.5
6.2	Lift motor output at S3 15% duty factor	(kW)	10	14	10		14	10	14	10	14	14	14	14
6.4	Battery voltage/capacity at 5-hour discharge	(V/Ah)	48 / 465, 620, 775	48 / 620, 775	48 / 465, 620, 775		48 / 620, 775	48 / 465, 620, 775	48 / 620, 775	48 / 465, 620	48 / 620	48 / 620, 775, 930	48 / 620, 775, 930	48 / 620, 775, 930
6.5	Battery weight	(kg)	700, 900, 1100	900, 1100	700, 900, 1100		900, 1100	700, 900, 1100	900, 1100	700, 900	900	900, 1100, 1300	900, 1100, 1300	900, 1100, 1300
Miscellaneous														
8.1	Type of drive control		Stepless	Stepless	Stepless		Stepless	Stepless	Stepless	Stepless	Stepless	Stepless	Stepless	Stepless
10.7***	Level of noise at the ear level of the driver according to EN 12 053:2001 and EN ISO 4871 in work LpAZ	(dB(A))	66	63	66		63	66	63	66	63	63	63	63
10.7.1***	Level of noise at the ear level of the driver according to EN 12 053:2001 and EN ISO 487, drive/lift/idle LpAZ	(dB(A))	58 / 73 / 50	61 / 69 / 48	58 / 73 / 50		61 / 69 / 48	58 / 73 / 50	61 / 69 / 48	58 / 73 / 50	61 / 69 / 48	61 / 69 / 48	61 / 69 / 48	61 / 69 / 48
****	Body tremble according to EN 13 059:2002	(m/s ²)	0.31	0.31	0.31		0.31	0.31	0.31	0.31	0.31	0.31	0.31	0.31
****	Hand tremble according to EN 13 059:2002	(m/s ²)	< 2.5	< 2.5	< 2.5		< 2.5	< 2.5	< 2.5	< 2.5	< 2.5	< 2.5	< 2.5	< 2.5

** Measured with standard seat

*** Inaccuracy of 4dB (A)

**** Body tremble measured with air suspended seat.

***** Max drive speed to fork direction 9 km / h

Continuing improvement may lead to changes in these specifications.

- Ast = Wa + R + a
- Ast = Working aisle width
- Wa = Turning radius
- a = Safety clearance = 2 x 100 mm
- R = $\sqrt{(l6 + x)^2 + (b12 / 2)^2}$
- l6 = Pallet length (1200 mm)
- b12 = Pallet width (800mm or 1000mm)
- Q = Lifting capacity, rated load
- c = Load centre (distance)

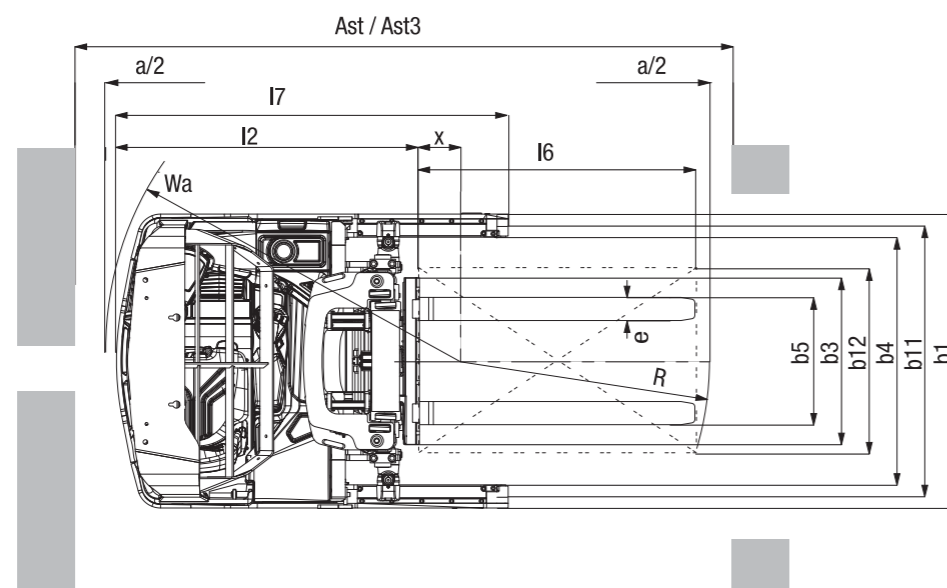
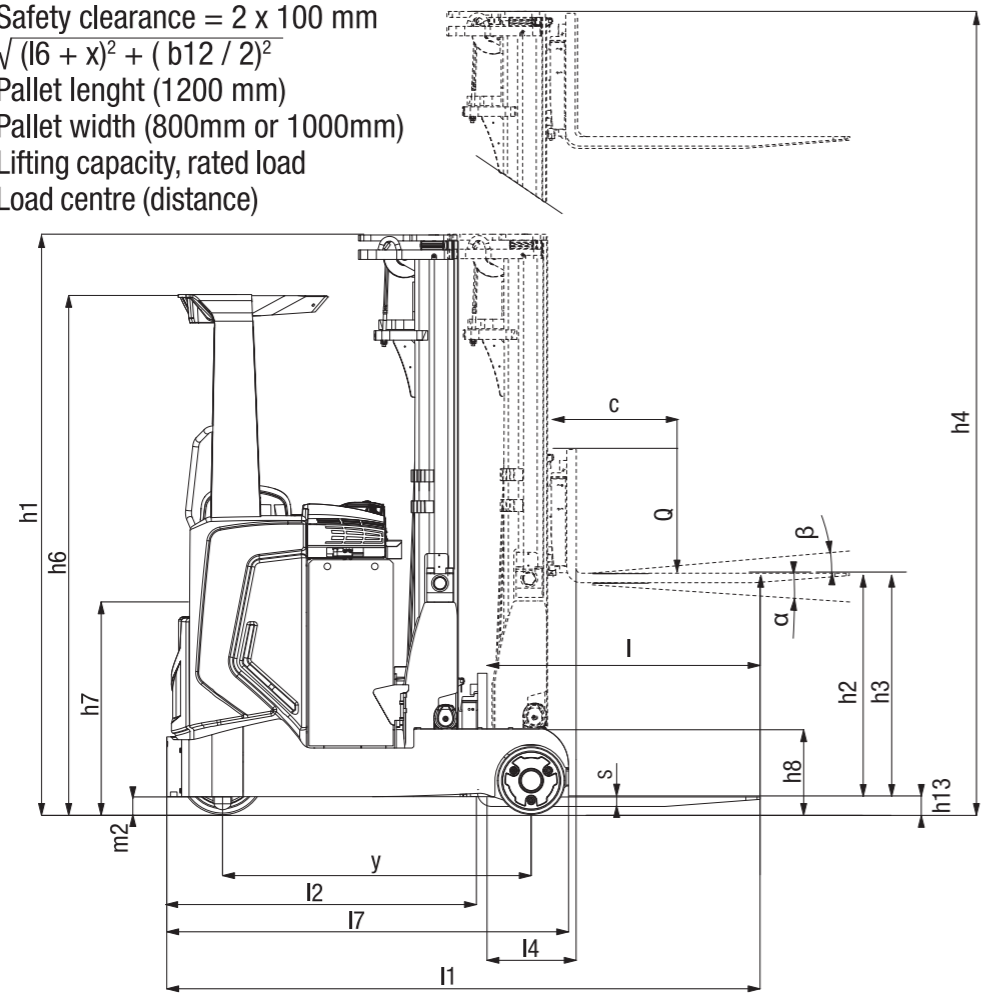

Mast Performance and Capacity

RB14N2S, RB16N2S, RB16N2, RB16N2C				
Mast Type	h3 + h13 mm	h1 mm	h2 + h13 mm	h4 ¹⁾ mm
Triplex	4800	2210	1560	5630
	5400	2410	1760	6230
	5700	2510	1860	6530
	5900	2577	1927	6730
	6300	2710	2060	7130
	7000	2943	2293	7830
	7500	3110	2460	8330

RB14N2HS, RB16N2HS, RB16N2HC				
Mast Type	h3 + h13 mm	h1 mm	h2 + h13 mm	h4 ¹⁾ mm
Triplex	8000	3297	2647	8830
	8500	3463	2813	9330
	9000	3785	3135	9830
	9000	3785	3135	9830

RB16N2H				
Mast Type	h3 + h13 mm	h1 mm	h2 + h13 mm	h4 ¹⁾ mm
Triplex	8000	3297	2647	8830
	8500	3463	2813	9330
	9000	3785	3135	9830
	9500	3952	3302	10330
	10000	4118	3468	10830
	10500	4285	3635	11330
	11000	4452	3802	11830
	11500	4618	3968	12330

RB20N2H, RB25N2X				
Mast Type	h3 + h13 mm	h1 mm	h2 + h13 mm	h4 ¹⁾ mm
Triplex	4800	2230	1580	5630
	5400	2430	1780	6230
	5700	2530	1880	6530
	5900	2597	1947	6730
	6300	2730	2080	7130
	7000	2963	2313	7830
	7500	3130	2480	8330
	8000	3297	2647	8830
	8500	3463	2813	9330
	9000	3785	3135	9830
	9500	3952	3302	10330
	10000	4118	3468	10830
	10500	4285	3635	11330
	11000	4452	3802	11830
	11500	4618	3968	12330

RB20N2X				
Mast Type	h3 + h13 mm	h1 mm	h2 + h13 mm	h4 ¹⁾ mm
Triplex	12000	4785	4135	12830
	12500	4952	4302	13330
	13000	5118	4468	13830
	13000	5118	4468	13830

1) Including load backrest

- h1 = Lowered mast height
- h2 + h13 = Free lift
- h3 + h13 = Lifting height
- h4 = Raised mast height

Model	Battery Capacity Ah	Battery Weight kg	4.33 (1000x1200mm crosswise)		4.34 (800x1200mm lengthwise)		L4 4,28	L2 4,20	L1 4,19	x 1,8
			Ast mm	Ast3 mm	Ast mm	Ast3 mm				
RB14N2S	465	700	2684	2466	2750	2666	463	1254	2404	281
	620	900	2740	2538	2816	2738	391	1326	2476	209
	775	1100	2798	2610	2883	2810	319	1398	2548	137
RB14N2HS	620	900	2748	2548	2825	2748	382	1336	2486	199
	775	1100	2806	2620	2892	2820	310	1408	2558	127
RB16N2S	465	700	2684	2466	2750	2666	463	1254	2404	281
	620	900	2740	2538	2816	2738	391	1326	2476	209
	775	1100	2798	2610	2883	2810	319	1398	2548	137
RB16N2HS	620	900	2748	2548	2825	2748	382	1336	2486	199
	775	1100	2806	2620	2892	2820	310	1408	2558	127
RB16N2C	465	700	2730	2502	2789	2702	510	1308	2458	327
RB16N2HC	620	900	2799	2592	2872	2792	420	1398	2548	237
RB16N2	465	700	2693	2463	2751	2663	513	1254	2404	331
	620	900	2748	2535	2817	2735	441	1326	2476	259
	775	1100	2804	2607	2883	2807	369	1398	2548	187
RB16N2H	620	900	2755	2545	2826	2745	432	1336	2486	249
	775	1100	2812	2617	2892	2817	360	1408	2558	177
RB20N2H	620	900	2784	2536	2830	2736	582	1336	2486	399
	775	1100	2837	2608	2895	2808	510	1408	2558	327
	930	1300	2892	2680	2961	2880	438	1480	2630	255
RB20N2X	620	900	2805	2560	2853	2760	572	1346	2496	389
	775	1100	2858	2632	2918	2832	500	1418	2568	317
	930	1300	2913	2704	2984	2904	428	1490	2640	245
RB25N2X	620	900	2805	2560	2853	2760	572	1346	2496	389
	775	1100	2858	2632	2918	2832	500	1418	2568	317
	930	1300	2913	2704	2984	2904	428	1490	2640	245

The wide load specialist... with narrow aisle agility.

SENSiA EX

Multi-way reach trucks

2.0 – 2.5 tonnes

options include

- Choice of masts up to 10.0 metres
- Hot storage specification
- Custom shop truck colour scheme
- Choice of fork positioner widths
- Wide range of working and warning lights
- Blue Spot pedestrian warning system
- Direction control by thumb or footswitch
- Load check scale
- USB power socket
- Dual roller bed battery changing table

capacities

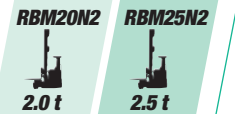

The Mitsubishi SENSiA EX multi-way reach truck range is ideal for precise and intuitive handling of wide and unusual loads of up to 2500 kg – and lifting up to 10 metres – in narrow aisles and on long shifts.

Six multi-directional travel modes, all-wheel steering and braking and powerful AC traction combine to deliver exceptionally agile, high-intensity performance. Its wide forks make long handling exact and effortless.

Comfortable and spacious, the award-winning SENSiA cabin, SDS and operator controls provides excellent all-round visibility and minimises operator fatigue.

- Mitsubishi TruckTool system for rapid service diagnostics and customer-specific truck optimisation by service engineer.



Passive Sway Control

- Mitsubishi SDS (Sensitive Drive System) provides intuitive driver-assist with graduated performance management according to steer angle, foot and finger actuator velocity – significantly contributing to safety.
- Spacious, comfortable, award-winning SENSiA cabin environment provides effortless 'total control' operation and minimises operator fatigue.
- Unique fingertip control armrest with integrated four-fingertip hydraulic control for reach, lift, tilt and spread plus direction and horn – all at the driver's constant touch.
- Broad battery change rollers are standard in all models.
- Exceptionally smooth 'no knock' transition between mast stages ensures exact performance throughout lift range.
- Passive Sway Control dampens any elevated load motion by allowing the chassis to move slightly to compensate.

Six travel modes

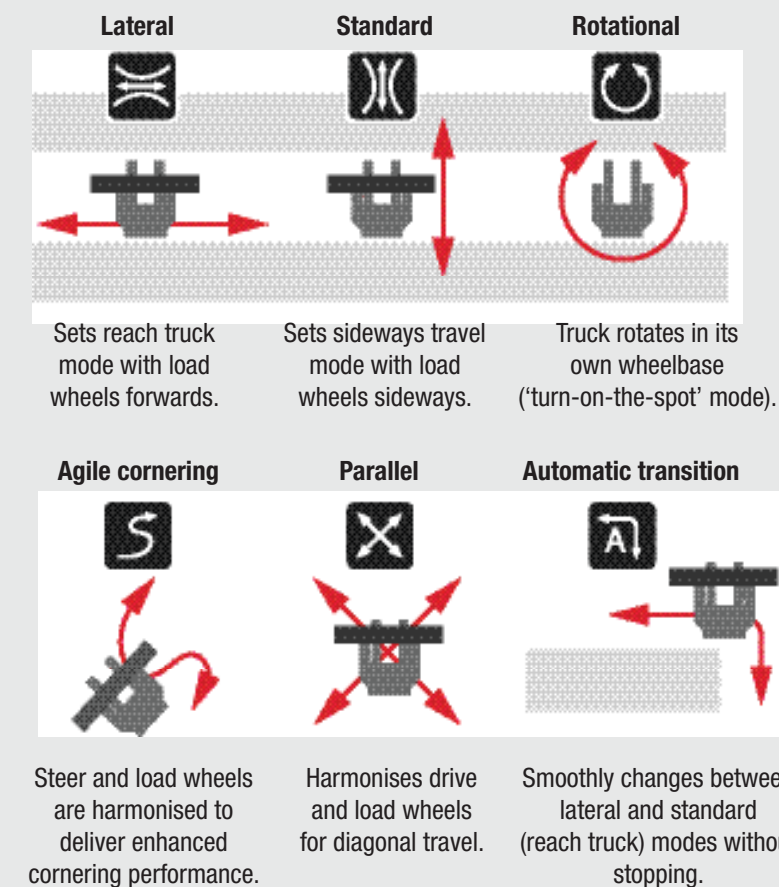

- The adjustable BE (beyond ergonomic) armrest fully supports the arm but leaves elbow free, reducing driver fatigue and long term injury.



Wide spread/tilt fork positioner



Clear upward views



Agile six-mode travel



Fatigue-free operation



Model shown: RBM20N2 SENSIA EX

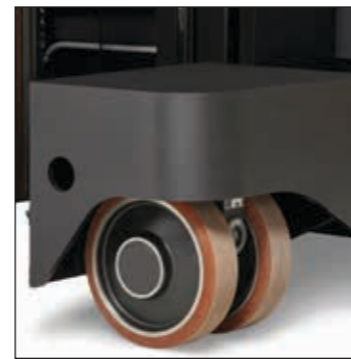

All-wheel steering and braking

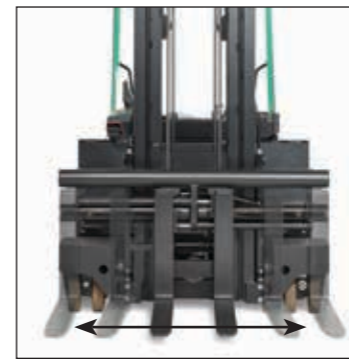

Wide spread/tilt fork positioner



Rapid TruckTool tailoring and diagnostics

Steering system

- Unlimited 360-degree all-wheel steering gives precise control with minimal effort
- Progressive steering enables easy manoeuvring at low speeds and effortless control when moving at speed

Brakes

- High-efficiency regenerative braking means effective control and reduced brake wear.
- Hydraulic load wheel brakes deliver agile performance.

Hydraulics

- Powerful AC hydraulic pump motor provides smooth lifting and lowering.

Electrical and control systems

- AC power on all motors delivers smooth performance, high torque and precise control - through the longest shifts.
- High performance ZAPI motor drive controller delivers robust and efficient traction control.
- Temperature control in drive and lift motors and controllers prevents damage from overheating.
- Battery rollers make changes quick, easy and safe.

Operator compartment and controls

- Spacious and comfortable operator compartment with clear views and fast, accurate fork positioning increases productivity and reduces risks of driver fatigue - even on the longest shifts.

- Easy-access compartment with ergonomic hand bars, low non-slip step and entry provides safe and effortless entry and exit.
- Folding steering wheel console with adjustment for column length and angle, lifts fully upwards for easy access and ensures optimum position for each driver.

- Multi-functional armrest with four-fingertip control keeps control for reach, lift, tilt, fork positioning, direction and horn all at the driver's constant touch.

- Multi-way-mode keypad control is within driver's easy reach - for easy selection of its 6 travel modes.

- Easy-to-understand display communicates key information to driver including guidance, warnings and alarms - encouraging good practice.

- EcoLogic and Professional modes (ECO/PRO) are quickly selectable by operator for extended shift life or enhanced performance.

Options include

- Choice of 2000kg and 2500kg capacities.
- Choice of masts up to 10.0m
- Choice of fork positioner widths (1700mm or 2200mm)
- BlueSpot pedestrian warning system alerts co-workers to trucks operating nearby.
- Working/drive lights to improve visibility in dark environments

- Choice of key switch or PIN code access.
- Load check scale (+/- 50kg) helps driver to identify overweight loads.
- Wide choice of seats, armrests and headrests for maximum comfort and minimum fatigue.
- Convenient USB Power socket for phone charging or other 5V personal equipment.
- Audio system and 3.5mm input jack for MP3 player etc.
- Quick, foot-operated battery-locking system



Characteristics				
1.1	Manufacturer		Mitsubishi	Mitsubishi
1.2	Manufacturer's model designation		RBM20N2	RBM25N2
1.3	Power source: (battery, diesel, LP gas, petrol)		Battery	Battery
1.4	Operator type: pedestrian, (operator)-standing, -seated		Seated	Seated
1.5	Load capacity	Q (kg)	2000	2500
1.6	Load center distance	c (mm)	600	600
1.8	Load wheel axle to fork face (forks lowered)	x (mm)	337	337
1.9	Wheelbase	y (mm)	1552	1552
Weight				
2.1	Truck weight with load, with maximum battery weight	kg	6888*	7784**
2.3	Axle loadings without load & with maximum battery weight, drive/load side	kg	2672 / 2 x 1108*	2907 / 2 x 1188**
2.4	Axle loading, mast forward, with nominal load, drive/load side	kg	591 / 2 x 3148*	521 / 2 x 3631**
2.5	Axle loading, mast retracted, with nominal load, drive/load side	kg	2292 / 2 x 2298*	2292 / 2 x 2298**
Tyres				
3.1	Tyres: PT=Power Thane, Vul=Vulkollan, drive / load side		Vul	Vul
3.2	Tyre dimensions, drive side	(mm)	Ø360 x 140	Ø360 x 140
3.3	Tyre dimensions, load side	(mm)	Ø285 x 75 x 2	Ø285 x 75 x 2
3.5	Number of wheels, load / drive side, (x=driven)		2+2/1x	2+2/1x
3.7	Track width (center of tyres), load side	b11 (mm)	1384	1384
Dimensions				
4.1	Fork tilt, forwards / backwards	α/β °	2.0 / 6.0	2.0 / 6.0
4.2	Height with mast lowered	h1 (mm)	see table	see table
4.3	Free lift	h2 (mm)	see table	see table
4.4	Lift height	h3 (mm)	see table	see table
4.5	Height, mast extended	h4 (mm)	see table	see table
4.7	Height to top of overhead guard	h6 (mm)	2190	2190
4.8	Seat- or stand height	h7 (mm)	1030	1030
4.10	Height of support legs	h8 (mm)	447	447
4.15	Fork height, fully lowered	h13 (mm)	50	50
4.19	Overall length	l1 (mm)	2630	2630
4.20	Length to fork face	l2 (mm)	1480	1480
4.21	Overall width	b1/b2 (mm)	1730	1730
4.22	Fork dimensions (thickness, width, length)	s / e / l (mm)	50 / 120 / 1150	50 / 120 / 1150
4.24	Fork carriage width	b3 (mm)	1700 / 2200	1700 / 2200
4.25	Outside width over forks (minimum/maximum)	b5 (mm)	500-1700 / 2200	500-1700 / 2200
4.26	Innerwidth of the support legs	b4 (mm)	900	900
4.28	Mast reach	l4 (mm)	610	610
4.32	Ground clearance at center of wheelbase, (forks lowered)	m2 (mm)	75	75
4.33/a	Working aisle width (Ast) with 1000 x 1200 mm pallets, load crosswise	Ast (mm)	2887	2887
4.34/b	Working aisle width (Ast3) with 800 x 1200 mm pallets, load lengthwise	Ast3 (mm)	2850	2850
4.35	Turning radius	Wa (mm)	1787	1787
4.37	Truck length including support legs	l7 (mm)	1982	1982
Performance				
5.1	Travel speed, with / without load	km/h	14 / 14	14 / 14
5.2	Lifting speed, with / without load	m/s	0.43 / 0.58	0.39 / 0.58
5.3	Lowering speed, with / without load	m/s	0.50 / 0.55	0.50 / 0.55
5.4	Reach speed, with / without load	m/s	0.1 / 0.1	0.1 / 0.1
5.8	Maximum gradeability, with / without load	%	11.0 / 17.0	11.0 / 17.0
5.9	Acceleration time (10 metres) with / without load	s	5.4 / 5.0	5.6 / 5.1
5.10	Service brake		Electric	Electric
Electric motors				
6.1	Drive motor capacity (S2 60 min. short duty)	kW	7.5	7.5
6.2	Lift motor output at S3 15% duty factor	kW	14	14
6.4	Battery voltage/capacity at 5-hour discharge	V/Ah	48 / 775, 930	48 / 775, 930
6.5	Battery weight	kg	1100, 1300	1100, 1300
6.6	Energy consumption according to EN 16796 cycle***	kWh/h	4.5	4.5
Miscellaneous				
8.1	Type of drive control		Stepless	Stepless
10.7****	Level of noise at ear level of the driver according to EN ISO 4871 in work LpAZ	dB(A)	68	68
10.7****	Level of noise at ear level of the driver according to EN ISO 487, drive/lift/idle LpAZ	dB(A)	80	80
Body	Whole-body vibration (EN 13 059:2002)	m/s ²	0.5	0.5
Hand	Hand-arm vibration (EN 13 059:2002)	m/s ²	<2.5	<2.5

* Weight values measured with 5700mm lift height mast & 775Ah battery

** Weight values measured with 10000mm lift height mast & 930Ah battery

*** Energy consumption values measured with 5700mm lift height mast

**** Inaccuracy of 4dB (A)

Continuing improvement may lead to changes in these specifications.

Model	Battery Capacity	Battery Weight	4.33 (1000 x 1200mm crosswise) Ast	4.34 (800 x 1200mm lengthwise) Ast3	L4	L2	L1	x
RBM20N2 & RBM25N2	Ah	kg	mm	mm	mm	mm	mm	mm
	775	1100	2887	2850	610	1480	2630	337
	930	1300	2887	2850	610	1480	2630	337

RBM20N2 // RBM25N2				
Mast Type	h1	h2	h3	h4
	mm	mm	mm	mm
TREV	2510	1800	5400	6200
	2610	1900	5700	6500
	2677	1967	5900	6700
	2810	2100	6300	7100
	3043	2333	7000	7800
	3210	2500	7500	8300
	3377	2666	8000	8800
	3543	2833	8500	9300
	3710	3000	9000	9800
	3877	3167	9500	10300
4043	3334	10000*	10800	

* only available for RBM25N2

Ast = $Wa + \sqrt{(l6 - x)^2 + (b12 / 2)^2} + a$
 Ast3 = $Wa + l6 - x + a$
 l6 = Pallet length (1200 mm)
 b12 = Pallet width (800 or 1200 mm)
 a = Safety clearance = 2 x 100 mm
 TREV = Triplex with free lift

