

TIRE DEALERS

Maximize Uptime With The Most Durable Products

GTS-50 TILT-BACK TIRE CHANGER

Coats® Reliability and
Durability Meets
Tilt-back



Two-Speed Electric Motor

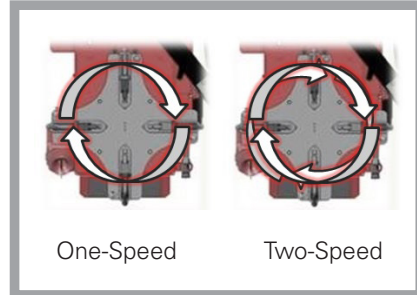

The Coats® two-speed electric motor provides total control based on application difficulty.

Hand Actuated Bead Loosener



The Bead Loosener offers point of use controls to the technician, providing direct line of site, reducing the risk of wheel damage.

Rim Protection Tower



Spring loaded mechanical design reduces wheel damage and stays locked in place.

To learn more about the Coats GTS-50 tire changer, or any of our other quality products, contact your authorized Coats distributor or call **1-855-876-3864** for the dealer nearest you.

COATS®

CONTACT US NOW

www.coatsgarage.com
or call 1-855-876-3864



GTS-50 TILT-BACK TIRE CHANGER

GTS-50 TILT-BACK TIRE CHANGER

RELIABLE. DURABLE. TILT-BACK.

SPECIFICATIONS

Wheel Handled	Alloy and Steel for Car and Light Truck
Rim Diameter	6" - 24" External
Maximum Tire Diameter	38" Max
Maximum Rim Width	15" Max
Bead Loosening System	Power in, out & freeze hand controlled air cylinder; up to 17"
Wheel Clamping System	4 Clamps, Air Cylinder Operated
Mount/Demount Mechanism	Tilt-back Tower
Helper Devices	Optional
Bead Seating Air Volume	NA
Inflation Gauge	60 psi
Air Supply Gauge	0 - 300 psi
Electric Drive System	1 HP, 2-Speed Electric Motor, 115v, 60 hz, 15amp
Footprint	35"w x 68"d x 78"h
Ship Weight	790 lbs.
Warranty	3 Year Parts, 6 Months Labor
Part Number	85610092

EQUIPMENT FOOTPRINT

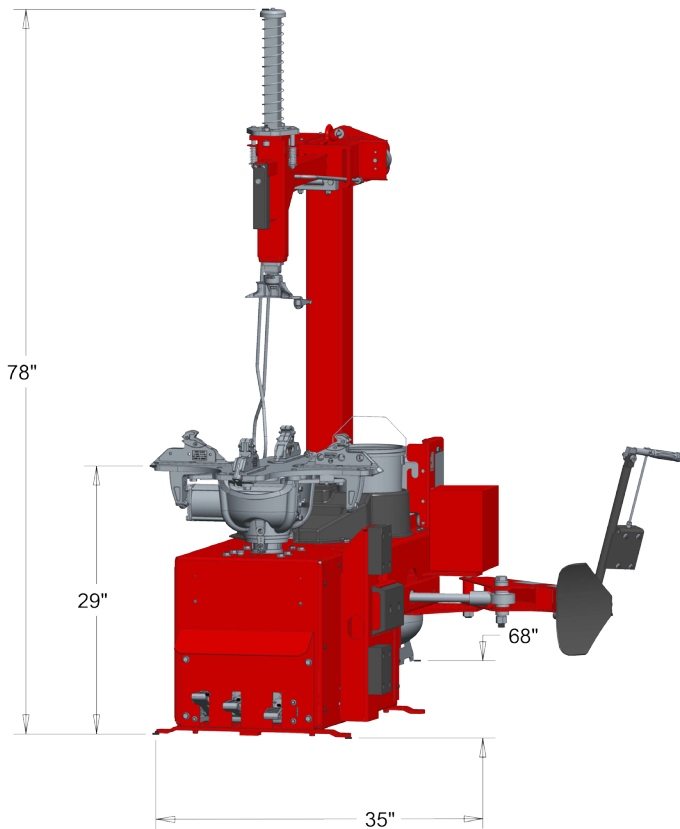

ACCESSORIES

* Included With Purchase

Part Number	Description
*8183606	Bead Loosener Shoe Socks - 2
*85009048	Paste Lube Bracket & Brush
*8183710	Paste Lube
*85607787	Grip-Max® Plus Clamps - 4
*8182961	Duckhead® Mount/Demount Tool Inserts - 2
*85000783	Lift Tool Socks - 10
*8183604	Steel Clamp Booties
*830084031	Nylon Duckhead® Mount/Demount Tool
*81827881	Steel Duckhead® Mount/Demount Tool
*81813541	Lift Tool
8560716108	Grip-Max® Plus Grips - 8

RECOMMENDED OPTIONAL ACCESSORIES



EL-X Express Lane Inflation System
(PN 85607770)

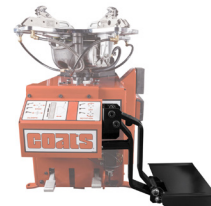

Point of Use Lift System
(PN 85608609)



Auxiliary Bead Sealer (ABS)
(PN 85606545)

COATS®