

## GTS-60 TILT-BACK TIRE CHANGER

Coats® Reliability and Durability Meets Tilt-back



### Rim Protection Tower



Spring-loaded-mechanical design reduces wheel damage and stays locked in place.

### Powered Roller Disk



The Coats® Powered Roller Disk provides bead loosening assistance, TPMS access, bottom bead removal and top bead mounting assistance.

### Two-Speed Electric Motor

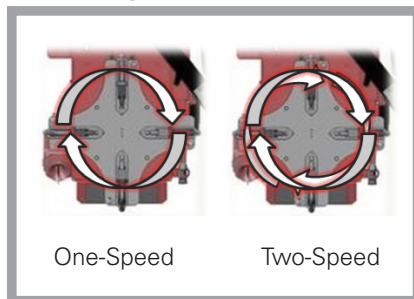

One-Speed

Two-Speed

The Coats® two-speed electric motor provides total control based on application difficulty.

To learn more about the Coats GTS-60 tire changer, or any of our other quality products, contact your authorized Coats distributor or call **1-855-876-3864** for the dealer nearest you.

# COATS®

## CONTACT US NOW

[www.coatsgarage.com](http://www.coatsgarage.com)  
or call 1-855-876-3864



GTS-60 TILT-BACK TIRE CHANGER

# GTS-60 TILT-BACK TIRE CHANGER

RELIABLE. DURABLE. TILT-BACK.

## SPECIFICATIONS

Wheel Handled	Alloy and Steel for Car and Light Truck
Rim Diameter	6" - 24" External.
Maximum Tire Diameter	38" Max
Maximum Rim Width	15" Max
Bead Loosening System	Power in, out & freeze hand controlled air cylinder; up to 17"
Wheel Clamping System	4 Clamps, Air Cylinder Operated
Mount/Demount Mechanism	Tilt-back Tower
Helper Devices	Powered Roller Disc
Bead Seating Air Volume	Vertical 3.8 Gallons in Tower
Inflation Gauge	60 psi
Air Supply Gauge	0 - 300 psi
Electric Drive System	1 HP, 2-Speed Electric Motor, 115v, 60 hz, 15amp
Footprint	60"w x 68"d x 78"h
Ship Weight	900 lbs.
Warranty	3 Year Parts, 6 Months Labor
Part Number	85610098

## EQUIPMENT FOOTPRINT

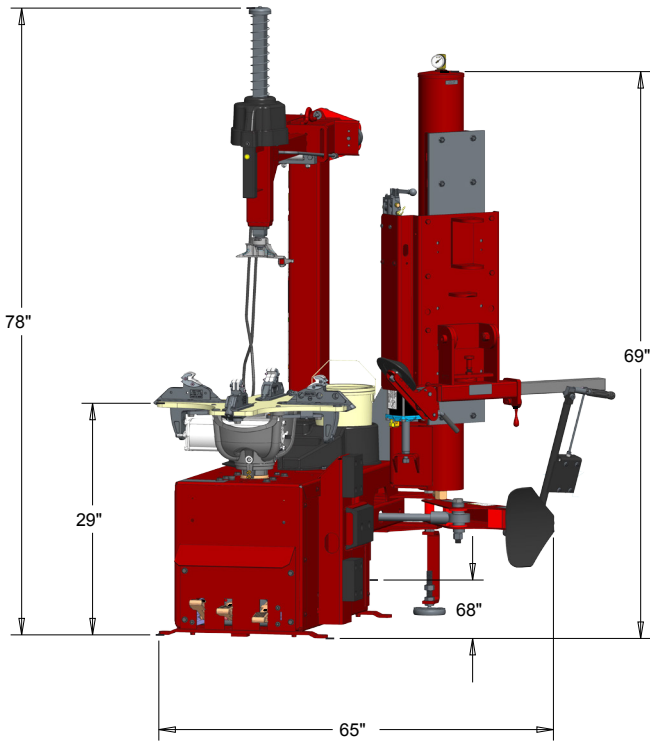

## ACCESSORIES

\* Included With Purchase

Part Number	Description
*8183606	Bead Loosener Shoe Socks - 2
*85009048	Paste Lube Bracket & Brush
*8183710	Paste Lube
*85607787	Grip-Max® Plus Clamps - 4
*8560716108	Grip-Max® Plus Grips - 8
*8182961	Duckhead® Mount/Demount Tool Inserts - 2
*85000783	Lift Tool Socks - 10
*8183604	Steel Clamp Booties
*830084031	Nylon Duckhead® Mount/Demount Tool
*81827881	Steel Duckhead® Mount/Demount Tool
*81813541	Lift Tool

## RECOMMENDED OPTIONAL ACCESSORIES



EL-X Express Lane  
Inflation System  
(PN 85607770)



Point of Use Lift System  
(PN 85608609)



Auxiliary Bead Sealer (ABS)  
(PN 85606545)

**COATS**