

## MODEL: TOE SERIES

Capacity: 2.5 - 50 Tons



### FEATURES

- Heat treated & chrome plated hydraulic rod provide longer seal life and optimum performance.
- Internal safety valve prevents toe jack from being used beyond its rated capacity.
- Housing welding onto the forged base ensures to be free of leakage problem.
- High strength Toe-Lift for long life use.
- Low toe heights fit in tight clearances.
- Swivel sockets for easy operation.
- Can be operated quickly by hand without a loading.
- Removable handle saves the handle force during operation.
- Max. Working Pressure 700 bar / 10,000 psi

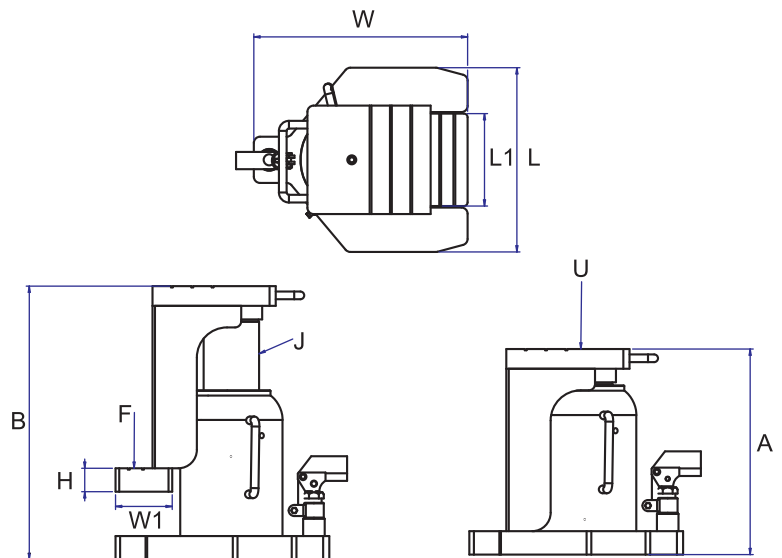

### SPECIFICATIONS

MODEL	TOP CAP. U(tons)	TOE-LIFT CAP. F(tons)	STROKE (mm)	MIN. HEIGHT A(mm)	MAX. HEIGHT B(mm)	PISTON ROD DIA. J(mm)	BASE DIMENSIONS LxW(mm)	HEIGHT H(mm)	TOE-LIFT L1xW1(mm)	WEIGHT (Kgs)
TOE-025	2.5	1.2	100	194	294	19	140X190	19	65X50	7.8
TOE-040	4	2	110	204	314	25	150X200	19	65X50	9.0
TOE-060	6	3	110	212	322	36	160X217	19	65X50	11.3
TOE-100	10	5	130	258	388	40	189X242	22	75X55	17
TOE-160	16	8	131	275	406	52	211X256	25	90X55	25.7
TOE-200	20	10	140	303	443	56	228X274	25	100X60	33.1
TOE-300	30	15	147	322	469	70	259X305	32	110X60	52
TOE-500	50	25	148	333	481	90	299X347	38	150X60	84