

*Ready to Perform
To Your Applications*

Pantograph Reach Truck



www.mitforklift.com.sg

© 2018 by MLAP. All Rights Reserved. All registered trademarks are the property of their respective owners. Printed in Singapore.

FMIT0130-02 (04/18)

PRESENTED BY :



Note: Performance specifications may vary depending on standard manufacturing tolerances, vehicle condition, types of tyres, floor or surface conditions, applications or operating environment. Trucks may be shown with non-standard options. Specific performance requirements and locally available configurations should be discussed with your Mitsubishi forklift truck dealers. Mitsubishi Forklift Trucks follows a policy of continual product improvement. For this reason, some materials, options and specifications could change without notice.

ESR/EDR Series
1.5 – 2.0 ton

Mitsubishi ESR/EDR Series Forklift Trucks

ADVANCED TECHNOLOGY

ADVANCED ENGINEERING



*Picture is for illustration purpose only.
Please contact your local dealers for more information.

Available in 3 different models with capacities ranging from 1.5~2.0 tons, Mitsubishi Forklifts trucks is ready to equip your business with the ultimate machines, ESR and EDR series Pantograph reach trucks.

With choices of single or double deep load handling capability, the new series reach trucks are built to deliver sturdy, power efficient and double the ability to handle sophisticated demand from the rising needs in materials handling industry.

This ultimate machine does not only provide the truck with revolutionary features but also cutting edge technologies to maximize productivity, and empower you the strength to perform.

PRECISE CONTROL FOR GREATER RELIABILITY

INDUSTRY-LEADING RUN TIME

ESR and EDR series of reach trucks has the ability to run up to two shifts on one battery charge, saving your business valuable operating time and money. All the major components – software, motors and controllers – are designed into one advanced system for superior energy efficiency, productivity and speed.

DYNAMIC LIFT SPEEDS

Built for productivity, this series of reach trucks achieves exceptional lift and travel speeds without compromising on control. One of the fastest in the industry, the reach truck's hydraulic system reaches a lifting speed of up to 0.8m/s – helping your operators move more pallets in less time.

ADVANCED BRAKE PERFORMANCE

The ESR / EDR series uses advanced regenerative braking, which puts kinetic energy back into the battery when the truck slows down or travels in reverse. This unique design also requires fewer parts and less maintenance. All of these features result in longer run times while maintaining consistent performance levels for even greater productivity.

SEALED COMPONENTS FOR GREATER RELIABILITY

These reach trucks feature sealed components for added protection in severe conditions, such as cooler or freezer applications. Sealed components offer greater reliability and require less maintenance over time, lowering your overall cost of operation today and in the future.

ADDED SECURITY

- Automatic speed reduction – reduces travel speed when the truck turns past a predetermined angle over-riding operator speed commands.
- Automatic parking brake – this brake automatically engages when the reach truck is initially turned on and when the operator steps off of the reach truck. For added security, the electromagnetic brake is only disengaged by operator command.

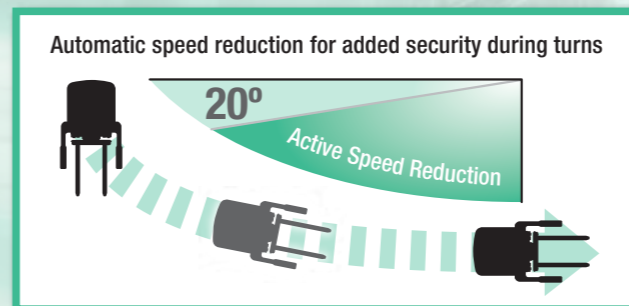

- Lifting: up to 11 meters height
- Lifting speed: up to 0.8m/s



PRODUCTIVE. POWERFUL. PERFORM.

Designed for stability from the ground up

The ESR / EDR series delivers industry-leading stability that is unmatched at high lift heights.

Rigid mast design

Rigid mast design

Robust scissors structure provides excellent load stability and smooth pantograph performance.

Suspended articulating drive axle helps to spread loading forces between the drive and caster wheels

AC technology is integrated into the reach truck design for even greater efficiency and productivity.

- ✓ Low energy consumption
- ✓ Longer run times
- ✓ Powerful acceleration
- ✓ Leading lift speeds
- ✓ Excellent energy management
- ✓ Smooth directional changes
- ✓ Less maintenance



DUAL-ARTICULATING LOAD WHEELS

Premium Load Wheels provide more contact area to the floor, helping to distribute load forces more evenly at very high lift height.

* Options available for straddle base leg



Excellent Visibility:

Operators experience confidence with the ESR / EDR series' enhanced design. Features such as wide channel spacing, stacked hydraulic hosing and a robust overhead guard with angled bars provide excellent visibility to the load and the surrounding area.



ULTIMATE COMFORT. ERGONOMIC BENEFITS

Exceptional comfort and control

Operators remain comfortable and in control thanks to these advanced features.

INFORMATIVE DIGITAL DISPLAY

Through one easy to read screen, operators can view key indicators such as current battery charge level, hour meter and performance modes. Various truck settings can be displayed on the panel.

Options available:

- ✓ Tilt Position Assist
- ✓ Integrated pre-height selector with lift height indicator
- ✓ 50mm or 100mm per way Integrated side shifter
- ✓ Integrated Fork Positioner with side shifter

INTUITIVE CONTROL HANDLE

Precise positioning of loads is no longer an issue to any operator with different skill level in equipment handling capability. Operators can now look forward to one of the easiest and sensitive operating multifunctional joystick in the industry, which integrates all controls function into one single control.



360° ELECTRONIC POWER STEERING

Maneuvering is now made easier with our highly responsive 360° electronic power steering. It is one of the most compact steering control in the industry that is ergonomically well aligned with your operator body without any contact while steering.

ERGO-CUSHIONED FLOOR AND BACKREST

Having discomfort while travelling on bumpy terrain? Fret no more. Our Ergo cushion floor pad is available to ease your operator from long hours of standing and fatigue on their foot and back.

SPECIFICATIONS

CHARACTERISTICS			ESR20N2		ESR23N2		EDR18N2	
1	Type		Single Reach		Single Reach		Double Deep Reach	
2	Power voltage		36		36		36	
3	Capacity at rated load center	lb kg	4,000	1,810	4,500	2,040	3,500	1,580
4	Capacity load center – distance from fork face	in mm	24	600	24	600	24	600
DIMENSIONS								
5	Maximum fork height	in mm	242	6,145	242	6,145	242	6,145
6	Free fork height	in mm	59	1,500	59	1,500	59	1,500
7	Fork width	in mm	3.9	100	3.9	100	3.9	100
8	Fork thickness	in mm	1.6	40	1.6	40	1.4	35
9	Fork spacing - out-to-out minimum	in mm	12	305	12	305	12	305
10	Fork spacing - out-to-out maximum ¹⁾	in mm	31.5	802	31.5	802	31.5	802
11	Tilt angle - forward / backward	deg	3° / 4°		3° / 4°		3° / 4°	
11a	Reach stroke	in mm	24	610	24	610	42	1,067
12	Mast width ²⁾	in mm	32.2	816	32.2	816	32.2	816
13	Baseleg opening	in mm	33 - 49	839 - 1,245	33 - 49	839 - 1,245	33 - 49	839 - 1,245
14	Baseleg width ³⁾	in mm	5.5	140	5.5	140	5	127
15	Overall length	in mm	76.1	1,932	76.1	1,932	78.1	1,983
16	Length to fork face	in mm	55	1,397	55	1,397	62.3	1,582
17	Overall chassis width	in mm	41.5	1,054	41.5	1,054	41.5	1,054
18	Overall lowered height	in mm	107	2,720	107	2,720	107	2,720
19	Overall lowered height to top of overhead guard	in mm	95	2,413	95	2,413	95	2,413
20	Overall height with extended mast	in mm	290	7,370	290	7,370	290	7,370
21	Step height	in mm	9.8	250	9.8	250	9.8	250
22	Battery roller height	in mm	7	178	7	178	7	178
23	Minimum outside turning radius	in mm	70.74	1,797	70.74	1,797	70.74	1,797
24	Minimum aisle - 90° stack - zero clearance	in mm	Please consult your Mitsubishi forklift truck dealer					
25	Load wheel centerline ⁴⁾	in mm	5.3	133	5.3	133	5.3	133
PERFORMANCE								
26	Grade clearance ⁵⁾	%	15.5		15.5		15.5	
27	Travel speed loaded/empty – standard ⁶⁾	mph km/h	7.5 / 7.5	12.1 / 12.1	7.5 / 7.5	12.1 / 12.1	7.5 / 7.5	12.1 / 12.1
28	Travel speed loaded /empty – high performance ⁶⁾	mph km/h	7.5 / 8.0	12.1 / 12.9	7.5 / 8.0	12.1 / 12.9	7.5 / 8.0	12.1 / 12.9
29	Lift speed loaded / empty (triplex) – standard	fpm m/s	75 / 120	0.38 / 0.60	75 / 120	0.38 / 0.60	75 / 120	0.38 / 0.60
30	Lift speed loaded / empty (triplex) – high performance	fpm m/s	90 / 160	0.45 / 0.80	90 / 160	0.45 / 0.80	90 / 160	0.45 / 0.80
31	Lower speed loaded / empty (triplex) – standard	fpm m/s	110 / 110	0.55 / 0.55	110 / 110	0.55 / 0.55	110 / 110	0.55 / 0.55
32	Lower speed loaded / empty (triplex) – high performance	fpm m/s	110 / 110	0.55 / 0.55	110 / 110	0.55 / 0.55	110 / 110	0.55 / 0.55
33	Gradeability - loaded / empty - maximum	%	9 / 9		9 / 9		9 / 9	
WEIGHT								
34	Truck weight - empty - without battery	lb kg	7,050	3,200	7,050	3,200	7,400	3,350
35	Battery weight - min	lb kg	2,000	910	2,000	910	2,000	910
36	Battery weight - max	lb kg	2,300	1,050	2,300	1,050	2,300	1,050
CHASSIS								
37	Chassis type (stand/sit)		Stand		Stand		Stand	
38	Wheelbase	in mm	61.5	1,562	61.5	1,562	61.5	1,562
39	Ground clearance - center of wheelbase	in mm	2.4	61	2.4	61	2.4	61
40	Ground clearance - lowest point at mast	in mm	2.4	61	2.4	61	2.4	61
41	Tire size - steer	in mm	13.5 x 5.5	343 x 140	13.5 x 5.5	343 x 140	13.5 x 5.5	343 x 140
42	Tire size - caster	in mm	7 x 4	180 x 100	7 x 4	180 x 100	7 x 4	180 x 100
43	Tire size - load wheels	in mm	5 x 3.62	127 x 92	5 x 3.62	127 x 92	5 x 3.62	127 x 92
44	Park Brake		Electromagnetic Disc		Electromagnetic Disc		Electromagnetic Disc	
ELECTRICAL								
45	Traction / pump / steer motor type		AC Induction		AC Induction		AC Induction	
46	Traction motor output (60 minute rating) – standard	hp kW	6.0	4.5	6.0	4.5	6.0	4.5
47	Traction motor output (60 minute rating) – high performance	hp kW	9.2	6.9	9.2	6.9	9.2	6.9
48	Pump motor output (5 minute rating)	hp kW	27.2	20	27.2	20	27.2	20
49	Steer motor output (60 minute rating)	hp kW	1.0	0.7	1.0	0.7	1.0	0.7
OTHER								
50	Battery maximum capacity - A/H (6 hour rating)		1,120		1,120		1,120	
51	Battery compartment length ⁷⁾	in mm	16.25	413	16.25	413	16.25	413
52	Battery compartment width	in mm	38.42	976	38.42	976	38.42	976
53	Battery compartment height	in mm	31.65	804	31.65	804	31.65	804

ESR20N2-EDR18N2

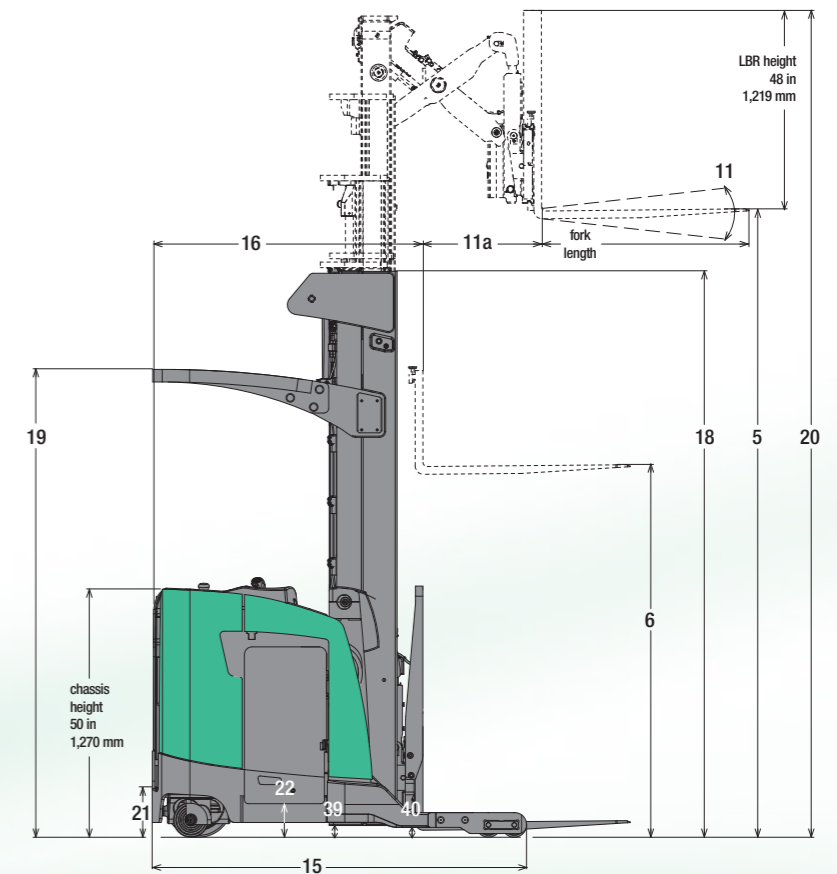
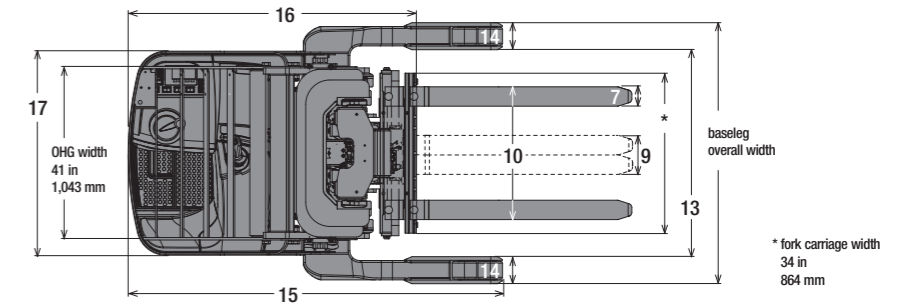

1. Maximum fork spacing 27.5 inches (698 mm) with 33 inch BLO.
2. Out-to-out dimension across mast outer channels.
3. 5.9 inches (150 mm) on single reach trucks with MFH over 332 inches (8430 mm).
4. 7.3 inches (186 mm) on single reach trucks with mast MFH above 332 inches (8430 mm).
5. Reduce grade clearance by 1.5% with 18.25 inch (463 mm) battery compartment length or 21.25 inch (539 mm) battery compartment length vs. 16.25 inch (412 mm) length.
6. Maximum speed attainable, after break-in period, varies with truck travel direction, weight, rolling resistance, mast height, options and battery condition.
7. 21.25 inch (539 mm) battery compartment length standard on chassis with MFH over 332 inches (8430 mm).