

MODEL:PM SERIES

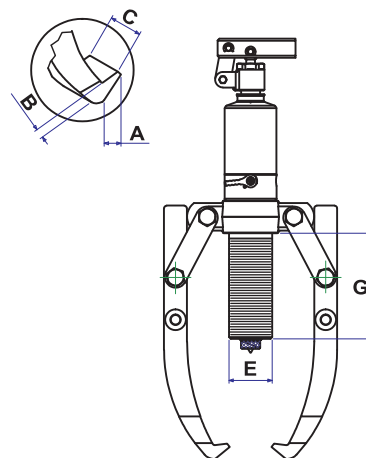

FEATURES

- Exchangeable 2 or 3 arm combination puller is very practical and economical.
- 360° Rotary Socket.
- Self-contained hydraulic pump and puller body with integral safety valve.
- Spring loaded live centering nut for easy job (removable).
- Four stages of foldable & removable handle saves the handle force during operation.
- Patented design of two stages stroking for PM2000 & PM3000, the first stage being as fast stroking for quickly connecting with object, and the second stage being as high hydraulic output for pulling job.
- The extension rods can be used for extra reach when necessary.

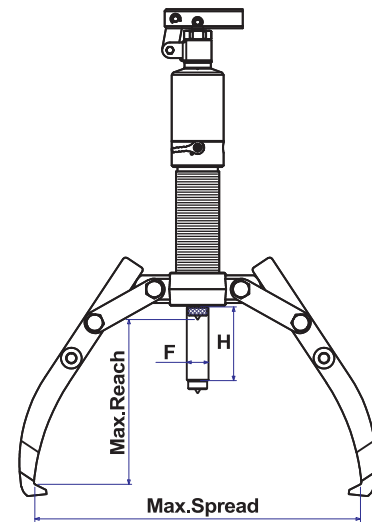

ACCESSORIES

Model No.	Part No.	Length of Long Arm (mm)	Max. Reach	Max. Spread
PM400	C0948	295	222	300
PM600	C0949	335	260	363
PM800	C0950	395	308	445
PM1200	C0951	435	340	420
PM2000	C0960	555	428	540
PM3000	C0961	555	428	620

SPECIFICATIONS

Capacity	Model No.	Reach (Max. mm)	Spread (Max. mm)	Stroke (mm)	Pump Tip (mm)			Jaw Tip (mm)			Weight (kg)
					H	E	F	G	A	B	
4 Ton	PM400	185	255	60	42	22	84	11	6	22	8.3
6 Ton	PM600	220	330	70	45	23	94	13	10	22	8.5
8 Ton	PM800	230	350	85	50	25	122	11	10	25	12.0
12 Ton	PM1200	270	375	85	60	28	118	14	10	29	17.2
20 Ton	PM2000	360	520	111	80	40	160	20	27	33	38.2
30 Ton	PM3000	360	550	111	98	50	155	20	27	38	50.6