



AJB300



AJ300



BJ500

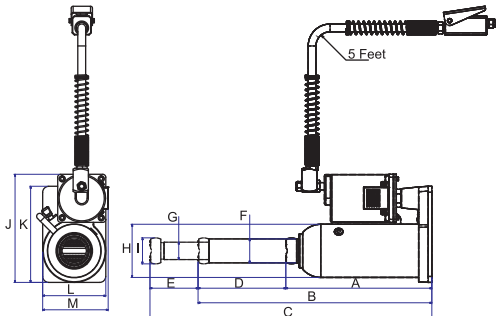

AJ system

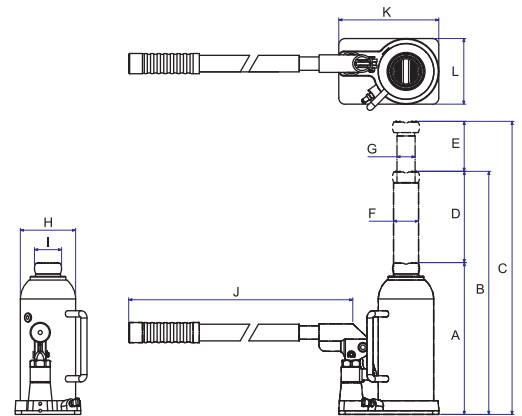

BJ system

FEATURES

- Low profile design for most of Industrial applications.
- Forging base as the strongest construction to catch the needs in Industry market.
- Design of housing welding onto the forged base prevent the leakage problem.
- Telescopic design of AJ120, AJ220, BJ120, BJ220, AJB1527 & AJB2035 reaches the extra height during operating to save time and labor cost.
- AJBseries are equipped with two large Dia. rubber wheels provide easy and well mobility works.
- Air/Hydraulic design make you free from pumping handle also with the most efficiency and time saving.

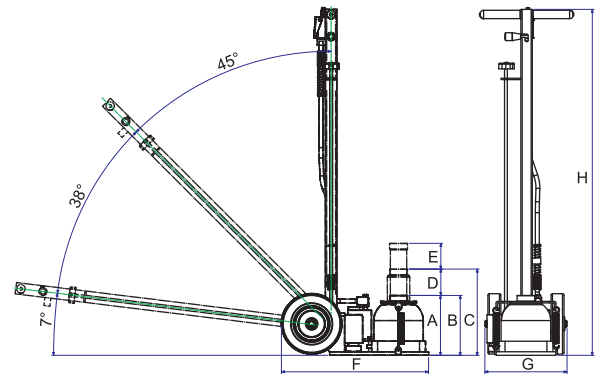

AJB system

SPECIFICATIONS

Model No.	Capacity (ton)	A (mm)	B (mm)	C (mm)	D (mm)	E (mm)	F (mm)	G (mm)	H (mm)	I (mm)	J (mm)	K (mm)	L (mm)	M (mm)	Handle Length (mm)	Weight (kg)
AJ120	12	243	389	469	146	80	40	29	88.5	43	180	160	105	109	290	10.0
AJ220	22	240	369	449	129	80	56	38	114	54	207	—	130	—	290	15.1
AJ300	30	279	423	—	144	—	65	—	140	—	235	—	150	154	290	26.0
AJ500	50	304	452	—	148	—	75	—	165.5	—	260	—	180	—	290	39.4
BJ120	12	243	389	469	146	80	40	29	88.5	43	507	160	105	—	500	8.8
BJ220	22	240	369	449	129	80	56	38	114	54	507	190	130	—	500	14.0
BJ300	30	279	423	—	144	—	65	—	140	—	507	235	150	—	500	27.0
BJ500	50	304	452	—	148	—	75	—	165.5	—	507	260	180	—	500	36.8
AJB1527	15/27	200	287	374	87	87	490	274	1155	—	—	—	—	—	—	38.5
AJB2035	20/35	200	287	374	87	87	490	274	1155	—	—	—	—	—	—	45.0
AJB300	30	247	345	—	98	—	460	274	1155	—	—	—	—	—	—	43.0
AJB500	50	266	367	—	101	—	490	274	1155	—	—	—	—	—	—	53.5

* All handle length is 630mm.