

MODEL: NSHS & NRHS SERIES

Capacity: 10 - 100 Ton

Stroke: 8 - 160 mm

Max. Working Pressure: 700 bar / 10,000 psi



FEATURES

- All cylinders are single acting with spring return.
- Pistons hard chromed.
- Cylinders inside roll-polished.
- Cylinders outside blasted with black nitriding finish.
- Use in combination with hand / foot pumps (Page 18-28), and accessories (page 71-77)

NRHS SERIES

- Get the fast retracting speed by Tension spring design.
- Enlarged Plunger size provide stronger gripping force.

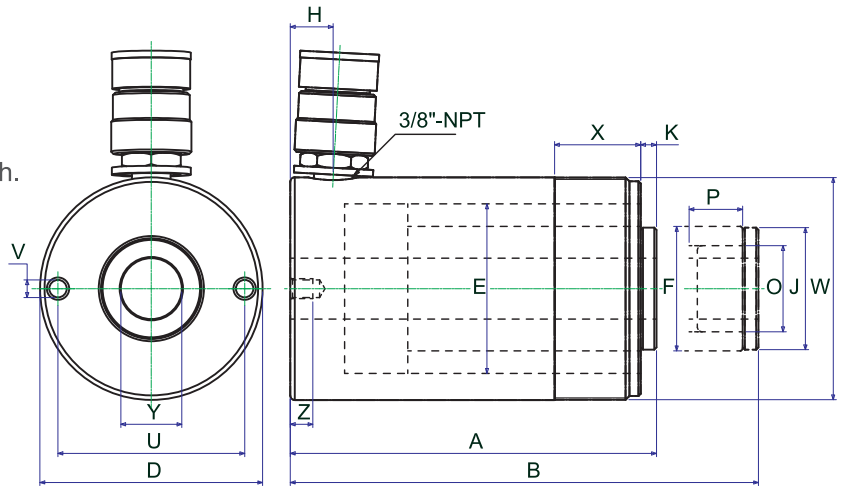

NSHS & NRHS SERIES, HOLLOW PLUNGER CYLINDERS

Model	Capacity (ton)	Stroke (mm)	Cylinder Effective Area (cm ²)	Oil Cap (cm ³)	HEIGHT(mm)		D Ø mm	E Ø mm	F Ø mm	H mm	J mm	K mm	O Ø UN	P mm	U mm	V Ø UN	Z mm	W Ø UN	X mm	Y Centre Hole (Ø mm)	Weight (kgs)		
					RETRACTED	EXTENDED																	
NSHS120	12	8	18.5	14.8	60	68	73	54	35	12.5	—	—	3/4"-16	16	50.8	5/16"-18	9	2 3/4"-16	33	19.5	1.8		
NSHS121		42	18.9	79	120	162		55		19			—	—		—	—	12.7	3.1				
NSHS1211		42	18.9	79	120	162		55		19			—	—		—	—	12.7	3.1				
NSHS123	20	76	18.9	143.2	184	260	98.5	55	75	19	54	7	1 9/16"-16	25	82.6	3/8"-16	9.4	3 7/8"-12	38	27	4.5		
NSHS202		51	34	173	162	213		75		19			54	7	1 9/16"-16	25	82.6	3/8"-16	9.4	3 7/8"-12	38	27	7.5
NSHS206		155	34	527	306	461		75		19			54	7	1 9/16"-16	25	82.6	3/8"-16	9.4	3 7/8"-12	38	27	13.5
NSHS302	30	65	47.8	310	178.5	243.5	117	90	65	21.5	59.9	0.5	1 7/8"-16	25	92	3/8"-16	14	4 1/2"-12	42	34	20.4		
NSHS306		160	47.8	763	330	490		90		65	21.5	59.9	0.5	1 7/8"-16	25	92	3/8"-16	14	4 1/2"-12	42	34	20.4	
NSHS603	60	76	89.6	680	247.5	323.5	158.6	125	90	32	89	12.5	2 3/4"-16	25	130	1/2"-13	14	6 1/4"-12	50	54	26.8		
NSHS606		152	89.6	1360	323.5	475.5		125		90	32	89	12.5	2 3/4"-16	25	130	1/2"-13	14	6 1/4"-12	50	54	34	
NSHS1003	100	76	143	1085	254	330	213	165	125	38	125	12	4"-16	30	178	5/8"-11	19	8 3/8"-12	60	79	50.1		
NRHS102	10	63.5	14.9	42.6	135.5	199	76.2	60	52.4	25.4	52	0.5	1 3/4"-12	15	60.3	1/4"-20UNC	10	—	—	19.5	4		
NRHS108		203	14.9	302.3	287.5	490.5		60		52.4	25.4	52	0.5	1 3/4"-12	15	60.3	1/4"-20UNC	10	—	—	19.5	8.5	
NRHS302	30	63.5	42.7	271	158.5	222	121	95	79.9	30	79.5	1.5	2 3/4"-12	20	95.3	7/16"-20UNF	14	4 3/4"-20UN	38	33.3	11.4		
NRHS306		152.5	42.7	651	247.5	400		95		79.9	30	79.5	1.5	2 3/4"-12	20	95.3	7/16"-20UNF	14	4 3/4"-20UN	38	33.3	11.4	